

(12) INTERNATIONAL APPLICATION PUBLISHED UNDER THE PATENT COOPERATION TREATY (PCT)

(19) World Intellectual Property  
Organization  
International Bureau



(43) International Publication Date  
13 May 2004 (13.05.2004)

PCT

(10) International Publication Number  
WO 2004/040285 A2

- (51) International Patent Classification?: G01N 27/00
- (21) International Application Number: PCT/GB2003/004667
- (22) International Filing Date: 30 October 2003 (30.10.2003)
- (25) Filing Language: English
- (26) Publication Language: English
- (30) Priority Data:
- |            |                               |    |
|------------|-------------------------------|----|
| 60/422,226 | 30 October 2002 (30.10.2002)  | US |
| 60/422,230 | 30 October 2002 (30.10.2002)  | US |
| 60/436,683 | 27 December 2002 (27.12.2002) | US |
| 60/436,685 | 27 December 2002 (27.12.2002) | US |
- (71) Applicant (for all designated States except US): INVERNESS MEDICAL LIMITED [GB/GB]; Beechwood Park North, Inverness IV2 3ED (GB).
- (72) Inventor; and
- (75) Inventor/Applicant (for US only): DAVIES, Oliver, William, Hardwicke [GB/GB]; An Cluaran, Croy, Invernesshire IV2 5PG (GB).
- (74) Agents: MERCER, Christopher, Paul et al.; Carpmaels & Ransford, 43-45 Bloomsbury Square, London WC1A 2RA (GB).
- (81) Designated States (national): AE, AG, AL, AM, AT, AU, AZ, BA, BB, BG, BR, BW, BY, BZ, CA, CH, CN, CO, CR, CU, CZ, DE, DK, DM, DZ, EC, EE, EG, ES, FI, GB, GD, GE, GH, GM, HR, HU, ID, IL, IN, IS, JP, KE, KG, KP, KR, KZ, LC, LK, LR, LS, LT, LU, LV, MA, MD, MG, MK, MN, MW, MX, MZ, NI, NO, NZ, OM, PG, PH, PL, PT, RO, RU, SC, SD, SE, SG, SK, SL, SY, TJ, TM, TN, TR, TT, TZ, UA, UG, US, UZ, VC, VN, YU, ZA, ZM, ZW.
- (84) Designated States (regional): ARIPO patent (BW, GH, GM, KE, LS, MW, MZ, SD, SL, SZ, TZ, UG, ZM, ZW), Eurasian patent (AM, AZ, BY, KG, KZ, MD, RU, TJ, TM), European patent (AT, BE, BG, CH, CY, CZ, DE, DK, EE, ES, FI, FR, GB, GR, HU, IE, IT, LU, MC, NL, PT, RO, SE, SI, SK, TR), OAPI patent (BF, BJ, CF, CG, CI, CM, GA, GN, GQ, GW, ML, MR, NE, SN, TD, TG).
- Published:  
— without international search report and to be republished upon receipt of that report
- For two-letter codes and other abbreviations, refer to the "Guidance Notes on Codes and Abbreviations" appearing at the beginning of each regular issue of the PCT Gazette.



WO 2004/040285 A2

(54) Title: PRECONDITIONING OF A SUBSTRATE IN A CONTINUOUS PROCESS FOR MANUFACTURE OF ELECTRO-CHEMICAL SENSORS

(57) Abstract: The present invention described a method of preconditioning a substrate in a web manufacturing process wherein the web manufacturing process includes a plurality of printing steps, the method comprising the steps of moving the substrate through the web manufacturing process under tension; heating the substrate as the substrate is passed through the printing steps, wherein the substrate temperature does not exceed a first predetermined temperature during the printing steps; and passing the substrate into a preconditioning station wherein the substrate is heated to a second temperature which exceeds the first temperature.

## PRECONDITIONING OF A SUBSTRATE IN A CONTINUOUS PROCESS FOR MANUFACTURE OF ELECTROCHEMICAL SENSORS

### FIELD OF THE INVENTION

The present invention relates, in general, to an improved process for manufacturing electrochemical sensors and, more particularly, to an improved web manufacturing process wherein a substrate is preconditioned prior to printing electrochemical sensor components.

### BACKGROUND OF THE INVENTION

Electrochemical sensors are used in a variety of diagnostic procedures, including the measurement of glucose in human blood. The manufacture of such electrochemical sensors involves the manufacture of millions of small strips which each include electrodes arranged in a sample receiving cell which is adapted to receive blood or other bodily fluids. The bodily fluids form complete circuit between the electrodes in the cell. The electrodes are generally coated with at least one reagent that reacts with the analyte (e.g. glucose) in the blood to form an intermediate analyte that may be measured by a meter adapted to measure current or charge at the electrodes. Manufacture of such electrochemical sensors requires the deposition of several layers of electrode material, insulation material and reagent in a very small space and the accuracy and arrangements of such layers is critical to the ultimate function of the device. Further, in order to hold down costs and meet demand, it is imperative that the electrochemical sensors be manufactured at very high speeds and with absolute accuracy of alignment between the layers.

Electrochemical sensors can be used for many applications. In one application, electrochemical sensor strip are inserted into specially adapted meters for self-monitoring of glucose or other analytes (such as fructosamine, haematocrit etc) in, for example, blood or interstitial fluid. Many analytes can be tested using such electrochemical sensors, depending upon the design of the electrochemical sensor, the arrangement of the

electrodes, the reagent used and other factors. Many of these applications, and in particular strips for testing glucose, require sensor layouts of a particular size and construction, where the manufacture is done within particular tolerances to render the electrochemical sensors having characteristics which are as predictable and repeatable as possible.

The manufacturing process is further complicated by the need to manufacture sensors many sensors very quickly where the sensors have very small cell sizes and, therefore, very small electrodes within very tight tolerances. When testing blood or interstitial fluid glucose, one of the main factors discouraging regular testing is the pain involved in extracting the required amount of blood or interstitial fluid. A larger volume typically requires a greater amount of pain than a smaller volume. Thus, it is advantageous to produce sensors that require a smaller amount of blood or interstitial fluid and therefore are less painful to use, encouraging more regular discrete or continuous testing. One way of requiring less analyte is to produce electrochemical sensor strips having a very small structural features such as, very small sample receiving cells and very small electrodes within those sample receiving cells, however, such small features more difficult to manufacture, particularly in an accurate and reproducible manner in order to produce accurate and reproducible analyte measurements.

Many methods may be used to manufacture electrochemical sensors, including such processes as rotogravure and cylinder screen printing. In rotogravure printing a cylinder is coated with a covering defining the shape of the feature (e.g. electrodes) to be printed. Further cylinders may be used to print further films or layers (e.g. enzymes or insulation layers).

Where an electrochemical sensor is fabricated by rotogravure printing of electrically conductive ink to form one or more electrodes on a flexible web, which may be polymeric. High quality print definition is possible using very thin inks. For the thicker inks and greater print thicknesses required when printing electrochemical sensors fixed flat screens have generally been used in single feed flat bed printing of electrochemical

sensors. Other methods, including methods of manufacturing electrochemical sensors using rotating printing structures have also been described.

In a web manufacturing process for electrochemical sensors, a web of substrate material is passed through a series of print stations. At each print station, a new layer of material such as, for example, electrode material, is deposited on the substrate or on a previously deposited layer using, for example, a screen printing process. In the screen printing process, the web is positioned under a screen and an ink, for example, a conductive ink used to make electrodes is pushed through selected portions of the screen to print a layer having a predetermined layout on the portion of the web positioned below the screen. Thus, it is possible build the electrochemical sensor on the substrate by moving the substrate from one print station to the next, printing each layer consecutively and cutting the individual sensor's from the finished web.

In one manufacturing method an electrode layer and at least a first reagent layer are manufactured by transporting a continuous web of the substrate past at least two print stations. The print stations may be cylindrical rotogravure print stations or cylinder screen print stations. However rotogravure (rotating an engraved cylinder) and cylinder screen printing (rotating a cylindrical screen/stencil) methods of printing suffer drawbacks when printing electrochemical sensors on a web. Rotogravure printing typically gives very thin print heights. The thick electrically conductive inks needed to produce the required electrode thickness for electrochemical sensors (especially those for blood glucose detection) are particularly likely to suffer from incomplete, inconsistent printing with the resultant reduction in electrochemical sensor quality, consistency and reliability. Rotogravure printing with carbon inks (which typically have a high solid content and can be quite viscous) for producing carbon electrodes is especially difficult as the solid/liquid phases in the ink can separate resulting in incomplete or uneven filling or emptying of the engraving from print to print. This can result in uneven print thicknesses and degradation of carbon electrode quality and consistency. Cylinder screen printing is well suited to single feed arrangements (as opposed to continuous web arrangements). Furthermore, the ability to manipulate the way the screen interacts with the printing medium, and hence

exert influence on the print quality by doing this) is limited because of the cylindrical nature of the screen. Also, the variety of stencils available to achieve the correct ink thickness for each type of ink (Carbon, silver/silver chloride, insulation, enzyme or other reagent layer) is not readily commercially available.

Electrochemical sensors for testing blood or interstitial glucose may also be produced in a multi step printing process using flat bed printers (such as Thieme or Svecia available from Kippax UK, Huddersfield, UK and Registerprint, London, UK) and metering an ink through screen stencils available from DEK Machinery, Weymouth, UK and BTP Craftsreen, Coventry, UK) arranged parallel to the flat substrate cards to be printed upon. This process has the advantage that the sensors can be produced in an accurate repeatable manner so that a user can compare results from time to time. Sheets of substrate for printing rows of strips thereon are passed through several flat bed printing stages with the rows perpendicular to the direction of travel. In this manufacturing process thin layers of ink are sequentially screen printed on to a polymeric substrate to form a large group of sensor strips. Firstly carbon ink may be laid down to form an electrode layer. Next an insulation ink layer may be laid down. Next a reagent layer, typically enzyme ink, may be laid down. Next a second enzyme layer may be laid down. Next an adhesive layer may be laid down. Finally, a hydrophilic layer may be laid down. A protective film may be placed on top of the sensor sheet before prior to cutting the sheet into rows and the rows into individual strips. A single sheet manufactured in this way of substrate may produce 500 or more sensor strips. These sensor strips are arranged in rows 0 to 9 perpendicular to the direction of travel of the substrate sheet through the flat bed printer (the direction of printing) with 50 sensor strips per row. Strips 1 to 50 in each row are each parallel to the direction of printing. Each sheet may be manipulated by hand between each stage. In particular following the four print steps (for printing carbon ink, insulation ink and two layers of enzyme ink) each sheet may be manipulated by hand into a cutting machine so that the cutting may be done along the rows separating one row of sensor strips from another. Next each row may be manipulated so as to be cut into 50 separate strips. These manipulation steps are time consuming and inefficient.

Therefore there exists the need for an improved process for the manufacture of electrochemical sensors, and in particular, for the manufacture of electrochemical sensors for measurement of markers in the body such as in blood or interstitial fluid (glucose, fructosamine, haematocrit and so on). There further exists a need for a high speed, predictable, reproducible way to manufacture sensor strips at a reasonable cost. Further, there exists a need for a high speed, predictable, reproducible way to manufacture sensor strips having very small features where each finished strip may be used to reliably, predictably and accurately measure analytes in bodily fluids in a reproducible manner.

In a continuous web manufacturing process for manufacturing electrochemical sensors, the sensor substrate, which may also be referred to as the web, may expand or stretch as it is heated up and placed under tension during the process. Each of the printing stations in the manufacturing process (i.e. the print stations where the carbon, insulation, and enzymes are deposited) may be followed by a drying station. In order to dry the inks to dry efficiently, the drier stations operate at temperatures of, for example 50-140 degrees centigrade. Furthermore to aid registration of the web through each printing station, the web is placed under tension. The substrate has to be kept under tension to control registration within the process, as a result, whenever the substrate is heated, for example to dry the inks after printing, the substrate may stretch unpredictably causing image size variation in subsequent prints.

The size of the image printed at each print station is determined by several factors including stencil size, ink viscosity, relative web and stencil/screen speed and substrate stretch at that point (both reversible and irreversible stretch). The image size between different printing steps may also vary in unpredictable ways significantly reducing yields. In one example, if the mismatch between image sizes between layers is greater than 300microns along the web the resulting sensor strip will not work and all of the strips in that batch will have to be scrapped.

The excessive image size variation is believed to be due to excessive and unpredictable stretching (due to heating and tension) and shrinking of the web substrate. It

would, therefore, be advantageous to design a web process wherein the web or substrate could be preconditioned to prevent unpredictable stretching during the manufacturing process.

#### SUMMARY OF THE INVENTION

The present invention is directed to a method of preconditioning a substrate in a web manufacturing process wherein the web manufacturing process includes a plurality of printing steps. In one embodiment, the method of the present invention includes the steps of moving the substrate through the web process under tension and heating the substrate as the substrate is passed through the printing steps. In this invention, prior to any printing steps, the substrate is passed through a preconditioning station which heats the substrate to a predetermined temperature which meets or exceeds any temperature the substrate sees during the remainder of the process. The temperature to which the substrate is heated during the preconditioning process may be approximately 160°C. The preconditioning station may also include at least one surface cleaning station adapted to remove impurities from the substrate.

In order to improve printing in a method according to the present invention, other steps may be included in the web manufacturing process. For example, the tension at which the substrate may be stretched is sufficient to ensure that tension is not exceeded during subsequent stages of the web process. Further, in one embodiment, predetermined tension is approximately 165N and the second predetermined temperature is approximately 140°C. In a further embodiment of the present invention, in the preconditioning step, the substrate is heated to a temperature sufficient to remove the irreversible stretch from the substrate as it moves through the web process.

#### BRIEF DESCRIPTION OF THE DRAWINGS

The novel features of the invention are set forth with particularity in the appended claims. A better understanding of the features and advantages of the present

invention will be obtained by reference to the following detailed description that sets forth illustrative embodiments, in which the principles of the invention are utilized, and the accompanying drawings of which:

Figure 1 is a schematic diagram depicting 8 sections of the web printing process.

Figure 2A is a schematic diagram depicting a first and second sections of the web printing process.

Figure 2B is a schematic diagram depicting a third, fourth, and fifth sections of the web printing process.

Figure 2C is a schematic diagram depicting a sixth and seventh sections of the web printing process.

Figure 3 is a schematic diagram depicting a humid environment around a fifth and sixth sections of the web printing.

Figure 4 is a bottom view depicting a humid environment around a fifth and sixth sections of the web printing.

Figure 5 is a perspective view of a pipe with perforations.

Figure 6 is a schematic diagram depicting a flood cycle

Figure 7 is a schematic diagram depicting a print cycle

Figure 8 is a schematic diagram depicting 2 different squeegee angles.

Figure 9 is a schematic diagram depicting 2 different squeegee positions.



Figure 10 is a schematic diagram depicting a screen snap distance.

Figure 11 is an exploded view of a preconditioning zone (211).

Figure 12 is an exploded view of the first drying zone (217).

Figure 13 is an exploded view of a second drying zone (224).

Figure 14 is an exploded view of a third drying zone (230).

Figure 15 is an exploded view of a fourth drying zone (236).

Figure 16 is an exploded view of a first cleaning unit (204).

Figures 17A-17D are views of an insulation layer to carbon layer with proper registration.

Figures 18A-18D are views of an insulation layer to carbon layer with improper registration when the artwork resulting from the screen 301 is stretched.

Figures 19A-19D are views of an insulation layer to carbon layer with improper registration when the art work from screen 301 has not stretched.

Figures 20A-20D are schematic diagrams depicting the print results for operator registration of the web using a first view guide for visual inspection during an initial registration process.

Figure 21A is an example of a sensor sheet with a first and second web view guides; first, second, third and fourth Y registration marks; and X registration marks.

Figure 21B is an exploded view of one row within a sensor sheet with a carbon X registration mark.

Figure 21C is an exploded view of one row within a sensor sheet with an insulation X registration mark over coating a carbon X registration mark.

Figure 22 is a schematic diagram of parameters X, Y, and  $\theta$  used to register the web printing process.

#### DETAILED DESCRIPTION OF ILLUSTRATIVE EMBODIMENTS OF THE INVENTION

Figure 1 is a schematic diagram depicting 8 sections of the web printing process according to the present invention. Section 1 is an unwinder unit 101. Section 2 is a pre-conditioning station 102. Section 3 is a carbon print station 103. Section 4 is an insulation print station 104. Section 5 is a first enzyme print station 105. Section 6 is a second enzyme print station 106. Section 7 is a rewinder unit 107. Section 8 is a punch 108. It will be understood by those skilled in the art that while the following description relates to a process and apparatus concerning these 8 sections, the process and apparatus of the invention can be embodied in greater or fewer numbers of sections. For example while 4 print stations are envisaged in this embodiment, one or more print stations could be used without departing from the scope of the invention. In one embodiment there are a minimum of two print stations for printing an electrode layer and a reagent layer.

In one embodiment of the present invention, Section 1 may be implemented using a substrate material unwind unit 101 such as, for example, a Martin Unwinder/Automatic Splice which is available from Martin Automatic Inc. in Rockford, IL. In this embodiment of the invention, Sections 2, 3, 4, 5 and 6, may be implemented using a modified Kammann Printer, which is available from Werner Kammann Maschinefabrik GmbH, model number 4.61.35, in Bünde, Germany. In this embodiment of the invention, Section 2 may be pre-conditioning unit 102. Pre-conditioning unit 102 may be used to precondition substrate 242 prior to printing and sections 3, 4, 5 and 6 may be used to screen print carbon, insulation, first enzyme and second enzyme inks onto a substrate 242. Section 7 may include rewinder unit 107 such as, for example, a Martin

Rewinder, which is available from Martin Automatic Inc. in Rockford, IL. Section 8 may include a punch 108 such as, for example, a Preco punch which is available from Preco Press, in Lenexa, Kansas as model number 2024-P-40T XYT CCD CE. While specific models of apparatus are mentioned, these pieces of apparatus may be varied and/or replaced and/or omitted altogether without departing from the scope of the invention as will be understood by those skilled in the art.

Figures 2A, 2B and 2C are schematic diagrams illustrating the path of substrate 242 as it passes through Sections 1-8 of a web printing process according to the present invention. In one embodiment of the Invention, the material used for substrate 242 may be a polyester material (trade name Melinex ® ST328), which is manufactured by DuPont Teijin Films. Substrate 242 is supplied in a roll of material, which may be, for example, nominally 350 microns thick by 370mm wide and approx. 660m in length. These dimensions of thickness and width have been found to be particularly suitable for the production of electrochemical sensors by flat screen printing on a web of substrate. This is because of the requirement for the material to be robust for printing yet manipulable through the apparatus and of sufficient width to accommodate a suitable quantity of sensors to render the process commercially viable. Substrate 242 may include an acrylic coating applied to one or both sides to improve ink adhesion. Polyester is a preferred material because it behaves satisfactorily at elevated temperatures and tensions used during the web process according to the present invention. While polyester and indeed Melinex are the preferred materials in one embodiment of the invention, the use of other materials can be envisaged by those skilled in the art from the description provided herein. Indeed, amongst other things, variations in material thickness, width and length can be envisaged, a larger width or length offering additional capacity for the production of sensors and a variation in material thickness in some circumstances aiding the preconditioning, or registration during printing. In a preferred embodiment of the present invention, prior to entering carbon print station 103, substrate 242 is exposed to a heat stabilization process, by heating the substrate up to 185 °C without placing it under significant tension to try and ensure that substrate 242 experiences minimum dimensional distortion during the web printing process where temperatures of between 140 and 160°C at tensions up to 165 N may be

encountered. Typically the tension used has been minimal, just to sufficient to drive the web through the heater. However, it has been found that despite this heat stabilization process, variations in registration from print step to print step can occur causing sensor failure. Thus, a preconditioning step has been introduced immediately prior to printing. As will be explained hereinafter, in the preconditioning step (section 1) the substrate is heated to a temperature (typically 160 °C) greater than any temperature it encounters during the later printing steps. In one preferred embodiment the substrate is also kept under tension (typically around 165N) during this preconditioning step. Indeed in this embodiment, the combination of preconditioning and placing under tension has greatly reduced the variations in print registration and improved the resultant product yield. In one embodiment of the invention, rolls of substrate 242 are spliced together in either unwinder unit 101 or rewinder unit 107 using splicing tape such as, for example, PS-1 Splicing Flat-back Paper Tape from Intertape Polymer Group.

Figure 2A is a schematic diagram depicting section 1 and section 2 of a web printing process according to one embodiment of the present invention. In Figure 2A, section 1 is an unwinder unit 101. Unwinder unit 101 includes first arbor 200, second arbor 201, first splice unit 202, and first accumulator 203. In Figure 2A, section 2 is pre-conditioning Station 102. Pre-conditioning Station 102 includes first cleaning unit 204, second splice unit 205 which typically is not used, inbound nip roller 206, second cleaning unit 207, load cell 208, first print roller 209, first drive roller 210 and first drier zone 211.

In the embodiment of the invention illustrated in Figure 2A, unwinder unit 101 consists of, for example, a Martin Unwinder/Automatic Splice which is used to facilitate the continuous movement of substrate 242 into pre-conditioning station 102 under a tension of approximately 80N. Unwinder unit 101 may include a first unwind arbor 200 and a second unwind arbor 201. Note that an arbor can also be referred to as a mandrel. First unwind arbor 200 holds a roll of substrate material 242 and continuously feeds substrate 242 into pre-conditioning station 102 of section 2. Second unwind arbor 201 holds a standby roll of substrate 242, which is automatically spliced to the end of the roll of substrate 242 from first unwind arbor 200 ensuring a semi-continuous supply of substrate

242. This continuous process repeats from first unwind arbor 200 to second unwind arbor 201. A substrate material accumulator 203 stores a predetermined length of substrate 242 and dispenses the stored substrate 242 into pre-conditioning station 102 of section 2 while the splicing operation takes place in first splice unit 202 (during which time both the first unwind arbor 200 and second unwind arbor 201 are stationary). The splice created is a butt splice with a length of splice tape on either side of the material at the joint. In order to ensure quality, approximately 10m of printed substrate may be discarded either side of the splice. First unwind arbor 200 and second unwind arbor 201 includes web edge guides (not shown) which guide substrate 242 into first splice unit 202. The web edge guides are adapted to prevent substrate 242 from wandering as it is being fed into first splice unit 202.

Typically the machine of the invention is set up to produce between 2 and 10 and more usually 6 rolls of substrate at any one time. For those print stations connected to a continuous supply of ink, the number of rolls to be used is not usually a problem. However, for the two enzyme print stations, to which a limited amount of ink is supplied, the number of rolls to be used is an important input parameter. Indeed the number of rolls to be used determines the amount of ink placed on the screen prior to start of the printing process. For example for a 6 roll run, 6 (or rather just more than 6) rolls worth of enzyme ink are placed on the screen prior to the start of printing in each of sections 5 and 6. Thus, the enzyme ink needs to be kept in readiness for printing throughout the print run to ensure consistent printing of enzyme over the whole life of the print run. A wall has been placed about the screen in the enzyme print stations to ensure that a sufficient amount of enzyme ink can be added to the screen without requiring the screen to be topped up during a run and also reducing the risk of the enzyme ink overflowing the screen and onto the web substrate running below it.)

In one embodiment of the present invention, substrate 242 is held under a tension of approximately 165N throughout the process in order to maintain registration of the four layers to be printed (typically the print registration tolerance is 300 $\mu$ m). The substrate 242 is also subjected to various temperatures of 140°C or less in order to dry the printed inks during each printing step. Due to this tension and temperature, there may be a

tendency for substrate 242 to stretch or expand during the process and consequently fall outside the registration tolerance. Indeed the image size variation from print stage to print stage and print run to print run as well as within the print run itself was unpredictable and higher than could be tolerated.

In the embodiment of the invention illustrated in Figure 2A, section 2 is a pre-conditioning station 102. Pre-conditioning occurs before any image is printed onto the substrate. Substrate 242 is pre-conditioned to reduce the amount of expansion and stretch within subsequent sections of the web process and also to aid the registration of substrate 242 through sections 3-6. Preconditioning station can heat substrate 242 to a temperature, which is not exceeded in the subsequent print steps. Typically this takes place under tension of between 150 and 180N more typically around 165N. However, in another embodiment pre-conditioning station 102 can heat substrate 242 to a temperature sufficient to remove the irreversible stretch from substrate 242, again optionally while under tension as described above.

In one embodiment of the invention, the substrate is heated to approximately 160°C in the preconditioning zone 211, which is illustrated in more detail in Figure 11. As explained above, in one embodiment of the present invention, the temperature to which substrate 242 is heated in pre-conditioning station 102 is not met or exceeded during subsequent processing of substrate 242, including subsequent drying steps. Subsequent print processes may compensate for the slightly larger image due to stretching caused by the process of pre-conditioning station 102 by the provision of a slightly larger stencil screen size (typically 750µm in the direction of travel of the web). The provision of new screens can be problematical. Other parameters can therefore be varied at each print station to accommodate a variation in image size without replacing the screen, such as the relative speed of the screen and the web. Nevertheless, there is a limit to the amount of image size variation that can be accommodated. It is therefore preferable to precondition the substrate as described herein reducing the overall image size increase and reducing the variation in said image size increase.

In one embodiment of the present invention, pre-conditioning station 102 also includes additional elements, which perform functions, which facilitate proper operation of a web manufacturing process according to the present invention. In pre-conditioning unit 102, there are two web cleaning units, a first cleaning unit 204 and a second cleaning unit 207 which clean the top and underside of substrate 242. First cleaning unit 204 and second cleaning unit 207 use tacky adhesive coated rollers to remove particulates from substrate 242 prior to any printing step. First cleaning unit 204 may be, for example, a cleaner commercially available from KSM Web Cleaners, model number WASP400, in Glasgow, United Kingdom. Second cleaning unit 207, for example, a cleaner commercially available from Teknek. Pre-conditioning station 102 further includes inbound nip roller 206 and a load cell 208. Inbound nip roller 206 is used to control the tension of substrate 242 (specifically the tension between inbound nip roller 206 and outbound nip roller 238). Inbound nip roller 206 is linked via a control system (not shown) to load cell 208. Substrate 242 is removed from second enzyme print station 106 in section 6 at a constant rate by outbound nip roller 238. Load cell 208 in Section 2 measures the tension of substrate 242 when it is moving through the web process according to the present invention. Inbound nip roller 206 adjusts its speed in order to control the tension at a predetermined set point. A typical substrate tension in a web manufacturing process according to the present invention would be approximately 150N to 180N and more specifically 160N to 170N, in this embodiment the tension is approximately 165N.

Figure 2B is a schematic diagram depicting section 3, section 4 and section 5 of a web printing process according to the present invention. In Figure 2B, section 3 is carbon print station 103. Prior to printing (a cleaning system is installed (available from Meech), which cleans the top side (print side) and underside of the substrate using a vacuum and brush system, the top brush and vacuum station 251 and bottom brush and vacuum station 250 are offset to one another. The top brush and vacuum station 250, contacts the substrate immediately prior to the chilled roller 212 and accumulator 213 and is the closest accessible point prior to carbon printing. The underside brush and vacuum station 251, contacts the substrate immediately after the substrate exits the pre-conditioning unit 102. Carbon print station 103 includes first chilled roller 212, second accumulator

213, second print roller 214, first vision sensor 215, second drive roller 216, first drier zone 217 and second chilled roller 218. In the embodiment of the invention illustrated in Figure 2B, section 4 is insulation print station 104. Insulation print station 104 includes third chilled roller 219, third accumulator 220, third print roller 221, second vision sensor 222, first Y registration system (not shown) at position 237A, third drive roller 223 and second drier zone 224. In Figure 2B, section 5 is first enzyme print station 105. First enzyme print station 105 includes fourth chilled roller 225, fourth accumulator 226, fourth print roller 227, third vision sensor 228, second Y registration system, at 237B (not shown), fourth drive roller 229 and third drier zone 230.

In a process according to the present invention, section 3 of the web manufacturing process is where carbon printing takes place. Of course, as will be appreciated by those skilled in the art, the number and type of printing processes can be varied without departing from the invention in its broadest context. For example, two carbon prints may be provided or one or more prints with carbon with metallic particles, silver/silver chloride ink or gold or palladium based inks may be used to provide an electrode layer in the electrochemical sensors. The insulation and reagent layers may also be varied in their composition, order of deposition, thickness of deposition and layout as well as in other parameters apparent to those skilled in the art from the embodiments described herein. In section 3, the carbon artwork for the electrochemical sensors manufactured in accordance with the present invention may be printed utilizing screen-printing. The basic components of the carbon print station 103 are illustrated in Figures 6 and 7. In particular, a suitable print station according to the present invention includes a screen 301, lower print roller 303, print roller 600, a flood blade 603, a squeegee holder 605 and a squeegee 606. In carbon print station 103, print roller 600 is second print roller 214. Screen 301 is of generally flat construction and typically comprises a mesh arranged to provide a negative of the artwork desired. Carbon ink is applied to the mesh and pushed through it during printing. At this stage the flat screen may be deformed slightly out of a flat shape by the weight of the ink (this is especially true for the enzyme print steps in which all of the ink to be used during the entire print run is usually deposited on the screen



at the start of the print run) and the pressure from the squeegee pushing the ink through the mesh stencil.

In a flood cycle process in accordance with the present invention, screen 301 is charged with ink 604 by moving squeegee 606, flood blade 603, print roller 600, and lower print roller 303, in first direction 608 which corresponds to the web movement of substrate 242. Screen 301 is moved in second direction 607 opposite to first direction 608 of substrate 242 for the flood cycle where ink 604 is charged onto screen 301.

In a subsequent print cycle process in accordance with the present invention, as illustrated in Figure 7, squeegee 606 transfers ink 604 through the screen 301 and onto substrate 242. During the print cycle, the squeegee 606, flood blade 603, print roller 600, and lower print roller 303 all move in second direction 607 which is opposite to the web movement of substrate 242. Screen 301 is moved in first direction 608 which corresponds to the web movement of substrate 242 for the print cycle where ink 604 is pushed through screen 301 and deposited on substrate 242. Thus during the print cycle the screen 301 moves in the same direction as the web substrate at the same or very nearly the same speed as the substrate. The screen 301 is substantially flat when at rest although in use it is pushed by the squeegee 606 towards the web becoming slightly distorted as this happens and substantially returning to its original shape once the squeegee 606 is removed. The screen 301 then moves in the opposite direction to the substrate as it is reloaded with ink 604 ready for the next print cycle. When the ink is loaded onto the screen 301 the weight of the ink may ever so slightly bend the screen. The screen 301 is at an angle to the direction of travel 608 of the web as it leaves the print station. This arrangement (the angle being typically around 10 to 30 degrees and more specifically around 15 degrees) improves ink release from the screen onto the substrate improving print definition and reproducibility. The screen to substrate angle, squeegee angle, screen to squeegee distance, squeegee to print roller position, snap distance, relative speeds of substrate and screen and squeegee pressure can all be used to control and optimize the resultant print definition and consistency across a card (One embodiment of a screen printing mechanism is described in more detail in issued US patent 4,245,554 which is incorporated by reference herein.

In particular, in carbon print station 103, the ink in question is a carbon ink. An example of a suitable carbon ink is set forth herein below. In this embodiment of the current invention, screen 301 is flooded with ink 604 prior to using squeegee 606 to transfer the ink 604 through the screen and onto substrate 242. The printed carbon artwork deposited on substrate 242 is then dried using, for example, hot air at 140°C directed onto the printed surface of the substrate using four separate drying banks within the first drier zone 217, which is illustrated in more detail in Figure 12.

Suitable ink for use in carbon print station include, but is not limited to, carbon with metallic particles, silver/silver chloride, gold based, palladium based conductive printable inks.

In one embodiment of the present invention, prior to the carbon printing process and immediately after drying, substrate 242 is passed over a first chilled roller 212 which is designed to rapidly cool substrate 242 to a predetermined temperature, typically room temperature (around 18-21 °C and typically 19.5 °C +/- 0.5 °C). In one embodiment of the web manufacturing process according to the present invention the surface of first chilled roller 212 is approximately 18°C. First chilled roller 212 may be cooled to an appropriate temperature using, for example, factory chilled water at around 7°C. The temperature of the roller can be controlled by controlling the flow rate and/or the temperature of the factory chilled water. After the printed carbon patterns are deposited in the printing process, substrate 242 is passed over second chilled roller 218. Reducing the temperature of substrate 242 and maintaining the temperature of substrate 242 is beneficial because cooler temperatures reduces the probability of ink drying on the screens during printing and creating blocks in the mesh. The use of chilled rollers in a web manufacturing process according to the present invention is also beneficial because it reduces the amount of stretch in substrate 242, reducing registration problems and the need to modify the process on the fly to compensate for such problems.

In one embodiment, the temperature of the chilled rollers is controlled dynamically by a feedback loop measuring the temperature of the chilled roller and controlling the water flow/temperature. Other methods of chilling the rollers can be envisaged by those skilled in the art from the embodiments described herein, for example, electrically powered refrigeration units.

In a process according to the present invention, section 4 of the web manufacturing process is where insulation printing takes place. In section 4, the insulation artwork for the electrochemical sensors manufactured in accordance with the present invention is printed utilizing screen-printing utilizing a generally flat screen. The basic components of the insulation print station 104 are illustrated in Figures 6 and 7. In particular, a suitable print station according to the present invention includes a screen 301, lower print roller 303, print roller 600, a flood blade 603, a squeegee holder 605 and a squeegee 606. In insulation print station 104, print roller 600 is third print roller 221.

In a flood cycle process in accordance with the present invention, screen 301 is charged with ink 604 by moving squeegee 606, flood blade 603, print roller 600, and lower print roller 303, in first direction 608 which corresponds to the web movement of substrate 242. Screen 301 is moved in second direction 607 opposite to first direction 608 of substrate 242 for the flood cycle where ink 604 is charged onto screen 301.

In a subsequent print cycle process in accordance with the present invention, as illustrated in Figure 7, squeegee 606 transfers ink 604 through the screen 301 and onto substrate 242. During the print cycle, the squeegee 606, flood blade 603, print roller 600, and lower print roller 303 all move in second direction 607 which is opposite to the web movement of substrate 242. Screen 301 is moved in first direction 608 which corresponds to the web movement of substrate 242 for the print cycle where ink 604 is pushed through screen 301 and deposited on substrate 242. One embodiment of the screen printing mechanism is described in more detail in issued US patent 4,245,554 which is incorporated by reference herein.

In movable flat screen printing, during printing a generally flat screen has a component of its motion which is in the same direction and at approximately the same speed as the substrate. Typically in each of the print stations, the substantially flat screen is at an acute angle (A in figure 6) to the substrate as the screen and substrate move away from a printing position (adjacent a print roller 200 in figure 6). Varying the relative speed of the substrate and the screen varies the size of the printed image in the direction of travel of the substrate, i.e. the X-direction.

The stencil screen used in each of the print stations typically consists of a resiliently deformable polyester or steel mesh stretched and attached to a rigid frame. One embodiment uses a polyester screen supplied by DEK Machinery, Weymouth, UK. The mesh is coated with a UV sensitive coating and in conjunction with a film positive the screen is exposed to a UV light source, developed and dried so that the coating dries on the screen to form a negative of the desired artwork image. With the aid of a squeegee, ink is passed through the open areas of the stencil and onto the substrate (giving a positive image formed by the ink on the substrate). The frame provides a means of mounting the mesh, and withstanding the forces imposed by the stretched mesh with minimum distortion and with standing the additional forces produced during printing.

In particular, in insulation print station 104, the ink in question is an insulation ink. An example of a suitable insulation ink is set forth herein below. In this embodiment of the current invention, screen 301 is flooded with ink 604 prior to using squeegee 606 to transfer ink 604 through the screen and onto substrate 242. The printed insulation artwork deposited on substrate 242 is then dried using, for example, hot air at 140°C directed onto the printed surface of the substrate using four separate drying banks within second drier zone 224, which is illustrated in more detail in Figure 13. An example of a suitable ink for use in insulation print station in a web manufacturing process according to the present invention is Ercon E6110-116 Jet Black Insulayer Ink which may be purchased from Ercon, Inc. In one embodiment of the invention, insulation artwork is registered to the carbon artwork in the X direction (along the machine) and the Y direction (across the machine) utilizing the techniques described herein. Other types of insulation ink may be

utilized as will be understood by those skilled in the art from the description herein. Furthermore different layers or different orders of layers can be used to provide a different order of layers and therefore different construction in the electrochemical sensors produced

In one embodiment of the present invention, before the insulation printing process and immediately after drying, substrate 242, including printed carbon and insulation patterns, is passed over third chilled roller 219 which is designed to rapidly cool substrate 242 to a predetermined temperature typically room temperature (around 17-21 °C and typically 19.5 °C +/- 0.5 °C). In one embodiment of the web manufacturing process according to the present invention, the surface temperature of the third chilled roller is approximately 18°C. Third chilled roller 219 may be cooled to an appropriate temperature using, for example, factory chilled water at around 7°C. Reducing the temperature of substrate 242 and maintaining the temperature of substrate 242 is beneficial because cooler temperatures reduces the probability of ink drying on the screens and creating blocks in the mesh. The use of chilled rollers in a web manufacturing process according to the present invention is also beneficial because it reduces the amount of stretch in substrate 242, reducing registration problems and the need to modify the process on the fly to compensate for such problems.

In a process according to the present invention, section 5 of the web manufacturing process is where the first enzyme printing takes place. In section 5, the enzyme ink artwork for the electrochemical sensors manufactured in accordance with the present invention is printed utilizing screen-printing and a movable generally flat screen as herein before described. The basic components of the first enzyme print station 105 are illustrated in Figures 6 and 7. In particular, a suitable print station according to the present invention includes a screen 301, lower print roller 303, print roller 600, a flood blade 603, a squeegee holder 605 and a squeegee 606. In first enzyme print station 105, print roller 600 is fourth print roller 227.

In a flood cycle process in accordance with the present invention, screen 301 is charged with ink 604 by moving squeegee 606, flood blade 603, print roller 600, and lower

print roller 303, in first direction 608 which corresponds to the web movement of substrate 242. Screen 301 is moved in second direction 607 opposite to first direction 608 of substrate 242 for the flood cycle where ink 604 is charged onto screen 301.

In a subsequent print cycle process in accordance with the present invention, as illustrated in Figure 7, squeegee 606 transfers ink 604 through the screen 301 and onto substrate 242. During the print cycle, the squeegee 606, flood blade 603, print roller 600, and lower print roller 303 all move in second direction 607 which is opposite to the web movement of substrate 242. Screen 301 is moved in first direction 608 which corresponds to the web movement of substrate 242 for the print cycle where ink 604 is pushed through screen 301 and deposited on substrate 242. One embodiment of the screen printing mechanism is described in more detail in issued US patent 4,245,554 which is incorporated by reference herein.

In particular, in first enzyme print station 105, the ink in question is an enzyme ink. An example of a suitable enzyme ink is set forth herein below. In this embodiment of the current invention, screen 301 is flooded with ink 604 prior to using squeegee 606 to transfer the ink 604 through the screen and onto substrate 242. The printed enzyme artwork deposited on substrate 242 is then dried using, for example, hot air at 50°C directed onto the printed surface of the substrate using two separate drying banks within the third drier zone 230, which is illustrated in more detail in Figure 14. An example of a suitable ink for use in first enzyme print station 105 in a web manufacturing process according to the present invention as summarized in Table 2.

Table 2.

Component	Supplier
Glucose Oxidase	Biozyme Laboratories
Tri-sodium Citrate	Fisher Scientific
Citric Acid	Fisher Scientific

Poly Vinyl Alcohol	Sigma Aldrich
Hydroxyethylcellulose (Nat 250 G)	Honeywell and Stein
	BDH/Merck LTD
	Sigma-Aldrich Chemical Co., UK
Potassium hexacyanoferrate III	Norlab Instruments Ltd., UK
DC.1500 Antifoam	BDH/Merck Ltd
Cabosil	Ellis and Everard Ltd
PVPVA	ISP Company Ltd
Analar Water	BDH/Merck Ltd

In one embodiment of the present invention, after the insulation printing process and immediately after drying, the substrate 242, including printed carbon and insulation patterns, is passed over fourth chilled roller 225 which is designed to rapidly cool substrate 242 to a predetermined temperature typically room temperature (around 17-21 °C and typically 19.5 °C +/- 0.5 °C).. In one embodiment of the web manufacturing process according to the present invention the surface of fourth chilled roller 225 is approximately 18°C. Fourth chilled roller 225 may be cooled to an appropriate temperature using, for example, factory chilled water at around 7°C. Reducing the temperature of substrate 242 and maintaining the temperature of substrate 242 is beneficial because cooler temperatures reduces the probability of ink drying on the screens and creating blocks in the mesh. The use of chilled rollers in a web manufacturing process according to the present invention is also beneficial because it reduces the amount of stretch in substrate 242, reducing registration problems and the need to modify the process on the fly to compensate for such problems.

Additionally, due to the high water content of the enzyme ink and the airflow due to the movement of the screen, it is crucial to ensure that the enzyme ink does not dry into the screen. The relative flow of air encountered by the moving screen dries the ink on the screen in a manner not normally observed in flat bed screen printers (such as Thieme flat bed printers) since the screen itself does not move within the machine, unlike the present invention. As well as the chilled roller alleviating this by ensuring the substrate is

cooled to around 18°C before it encounters the enzyme screen-printing step, the screen loaded with enzyme ink is humidified during printing. In one embodiment, humidification is substantially continuous. There may be topside, underside and/or side screen humidification and indeed all three may be provided. An arrangement of pipes provides a substantially constant stream of humidified air above, below and sideways onto the screen respectively, ensuring the water content of the ink, is maintained at a constant level. A suitable arrangement for providing topside, underside and/or side screen humidification according to the present invention is illustrated in Figures 3, 4 and 5. The amount and arrangement of humidification means (typically pipes carrying humidified air) will depend, amongst other things, upon the amount of humidification required, the water content of the ink, the humidity and temperature of the surrounding air, the temperature of the substrate as it approaches the enzyme print station, the temperature of the print roller, the size of the screen and the exposure of the screen to the surrounding (unhumidified air). In one embodiment a pipe 304 comprising one or more rows of holes 400 delivers humidified air across the whole underside of the screen during one stroke of the screen back and forth. Pipes (not shown) above and to the operator side of the machine deliver humidified air flows 300 and 304 (see figure 4).

Typically all the enzyme ink required for that print run is placed on the screen at or prior to the start of the print run. Since the enzyme ink is composed of a large part of water (typically between 55 and 65% by weight, more typically around 60 % by weight, the ink is prone to drying out over the lifetime of the run. This risk can be alleviated by providing humidification around the screen loaded with enzyme ink. Alternatively or more typically in addition the substrate can be chilled prior to encountering the enzyme (or indeed any) print station by the use of chilled rollers as herein described. Typically the temperature of the substrate is controlled to be less than or equal to the temperature of the room. However, the temperature of the substrate is kept above the dew point for the atmosphere in the room. If the room is at 60% humidity then the dew point may be 15 °C. If the temperature of the substrate falls below this then, condensation can occur on the substrate potentially compromising any subsequent print run, especially any subsequent print run with water soluble ink such as enzyme ink. Control of the substrate temperature,



for example between the limits of room temperature and dew point, may therefore be important for a successful print run. Control of temperature of and/or time passing over chilled rollers 212, 219, 225, and 231 is important in controlling substrate temperature. A feedback control loop can be used to measure the substrate temperature for example relative to the room temperature and/or dew point (given the room's humidity) to control the temperature of the chilled rollers and the temperature of the substrate as it leaves the roller and approaches the next print station.

Figure 2C is a schematic diagram depicting section 6 and section 7 of a web printing process according to the present invention. In Figure 2C, Section 6 is second enzyme print station 106. Second enzyme print station 106 includes fifth chilled roller 231, fifth accumulator 232, fifth print roller 233, fourth vision sensor 234, fifth drive roller 235, fifth drier zone 236, Y registration system 237 and outbound nip roller 238. In the embodiment of the invention illustrated in Figure 2C, section 7 is rewinder unit 107. Rewinder unit 107 includes steering mechanism 239, first rewind arbor 240 and second rewind arbor 241.

In a process according to the present invention, section 6 of the web manufacturing process is where the second enzyme printing takes place. In section 6, the enzyme ink artwork for the electrochemical sensors manufactured in accordance with the present invention is printed utilizing screen-printing. The purpose of applying 2 coatings of the enzyme ink is to ensure complete coverage of the carbon electrodes and so that the electrodes are substantially even and free of voids. The basic components of the second enzyme print station 106 are illustrated in Figures 6 and 7. In particular, a suitable print station according to the present invention includes a screen 301, lower print roller 303, print roller 600, a flood blade 603, a squeegee holder 605 and a squeegee 606. In second enzyme print station 106, print roller 600 is fifth print roller 233.

In a flood cycle process in accordance with the present invention, screen 301 is charged with ink 604 by moving squeegee 606, flood blade 603, print roller 600, and lower print roller 303, in first direction 608 which corresponds to the web movement of substrate

242. Screen 301 is moved in second direction 607 opposite to first direction 608 of substrate 242 for the flood cycle where ink 604 is charged onto screen 301.

In a subsequent print cycle process in accordance with the present invention, as illustrated in Figure 7, squeegee 606 transfers ink 604 through the screen 301 and onto substrate 242. During the print cycle, the squeegee 606, flood blade 603, print roller 600, and lower print roller 303 all move in second direction 607 which is opposite to the web movement of substrate 242. Screen 301 is moved in first direction 608 which corresponds to the web movement of substrate 242 for the print cycle where ink 604 is pushed through screen 301 and deposited on substrate 242. One embodiment of the screen printing mechanism is described in more detail in issued US patent 4,245,554 which is incorporated by reference herein.

In particular, in second enzyme print station 106, the ink in question is an enzyme ink. In this embodiment of the current invention, screen 301 is flooded with ink 604 prior to using squeegee 606 to transfer the ink 604 through the screen and onto substrate 242. The printed enzyme artwork deposited on substrate 242 is then dried using, for example, hot air at 50°C directed onto the printed surface of the substrate using two separate drying banks within a fourth drier zone 236, which is illustrated in more detail in Figure 15. An example of a suitable ink for use in second enzyme print station 106 is the same as the enzyme ink used in first enzyme print station which is described in aforementioned Table 2.

In one embodiment of the present invention, after the second enzyme printing process and immediately after drying, the substrate 242, including printed carbon, insulation, and enzyme ink patterns, is passed over fifth chilled roller 231 which is designed to rapidly cool substrate 242 to a predetermined temperature. In one embodiment of the web manufacturing process according to the present invention the surface of the fifth chilled roller 231 is approximately 18°C. Fifth chilled roller 231 may be cooled to an appropriate temperature using, for example, factory chilled water at around 7°C. Reducing the temperature of substrate 242 and maintaining the temperature of substrate 242 is

beneficial because cooler temperatures reduces the probability of ink drying on the screens and creating blocks in the mesh. The use of chilled rollers in a web manufacturing process according to the present invention can also be beneficial because it reduces the amount of stretch in substrate 242, reducing registration problems and the need to modify the process on the fly to compensate for such problems.

Additionally, due to the high water content of the enzyme ink and the airflow due to the movement of the screen, it is crucial to ensure that the enzyme ink does not dry into the screen. As well as the chilled roller alleviating this by ensuring the substrate is cooled to 18°C before it encounters the enzyme screen-printing step, there is also topside and/or underside and/or side screen humidification, which can provide a stream of humidified air above and below the screen, ensuring the water content of the ink is maintained at a constant level. Typically the humidified air flows constantly over the screen. A suitable arrangement for providing topside and underside screen humidification according to the present invention is illustrated in Figure 3.

Second enzyme print station 106 may include outbound nip roller 238, inspection system 237 for inspecting registration, third Y registration system at 237C (not shown) and barcode station (not shown). Outbound nip roller 238 helps control the tension of substrate 242 (specifically the tension between inbound nip roller 206 and outbound nip roller 238). Substrate 242 is removed from second enzyme print station 106 at a constant rate by outbound nip roller 238. The Y registration system (not shown) at positions 237A, 237 B and 237C controls the Y registration (i.e. across the web) of each print cycle during printing by utilizing the first Y registration marks 2101, second Y registration marks 2102, third Y registration marks 2103, fourth Y registration marks 2104 which are illustrated in Fig 21A. In one embodiment of the invention, first Y registration marks 2101, second Y registration marks 2102, third Y registration marks 2103, and fourth Y registration marks 2104 may correspond, respectively, to the Y registration of carbon print station 103, insulation print station 104, first enzyme print station 105, and second enzyme print station 106. Each Y registration marks comprises 2 triangles that are juxtaposed in an orientation

that approximates a rectangle. In one embodiment the Y registration system located at positions 237A, 237B and 237C can be implemented by an Eltromat DGC650 from Eltromat GmbH in Leopoldshöhe, Germany.

In one embodiment of the present invention, the inspection system 237, may be implemented using the Eltromat Inspection System, model number PC3100 HD, which is commercially available from Eltromat GmbH in Leopoldshöhe, Germany. The inspection system 237 has a vision component that inspects the registration marks illustrated in Figures 17A to 19D and/or figure 20D and can be used as a tool in assessing whether a sensor sheet 2106 should be rejected (for example by recording inspection results against a barcode in a database).

Registration issues in the Y dimension (which can be altered during printing by the registration system (not shown) which is located at 237A, 237B and 237C and/or inspected by inspection system 237 after all print stages are complete) may be ascribed to variations in web tension or non-uniform distortions to the substrate 242. In an embodiment of the invention, the barcode station comprises the following commercially available components barcode printer (model number A400 from Domino UK Ltd. in Cambridge, United Kingdom), barcode traverse system (Scottish Robotic Systems in Perthshire, Scotland), and barcode reader (RVSI Acuity CiMatrix in Canton, MA). The barcode station (no shown) labels each row of the sensor sheet 2106 with a 2 dimensional bar code. This provides each row of sensors a unique identifier code, batch/Lot number identification, the sensor sheet number, and row number. The barcode station also reads barcode immediately after printing to verify that the barcode has printed properly and provides a visual indicator to the machine operators. The barcode and process information from sections 2 to 6 are stored in a database and used later to identify and subsequently reject/accept cards for future process.

Rewinder unit 107 consists of, for example, a Martin Automatic Rewind System. This is the last section of the machine and allows the continuous rewind of substrate 242. Rewinder unit 107 consists of a first rewind arbor 240 and second rewind

arbor 241. First rewind arbor 240 holds a roll of substrate material 242 and continuously pulls material from second enzyme print station 106. Second rewind arbor 241 holds a standby roll of material, which automatically splices a first roll of substrate 242 into a second roll on the completion of the roll of substrate 242 from first rewind arbor 240. This continuous process repeats from first rewind arbor 240 to second rewind arbor 241. A flying splice, which occurs while the substrate 242 is still moving, is used to enable the continuous rewind of substrate 242. The splice is placed directly onto a fresh roll of substrate material 242 which is primed with double sided pressure sensitive adhesive.

Figure 3 is a schematic diagram depicting the humid environment around a fifth and sixth sections of the web printing. The basic components used to provide the means for humidification of the web printing environment are illustrated in Figure 3 which includes top humid air 300, screen 301, bottom humid air 302, lower print roller 303, pipe 304 comprising multiple perforations 400, substrate 242, and either fourth print roller 227 or fifth print roller 233. Humidification and temperature is set to try and ensure that the properties of the enzyme ink do not change to any significant extent over time during the flood and print cycle and preferably over the life of the print run. In particular, it is desirable that the viscosity and water content of the enzyme ink not change over time during the flood and print cycle and preferably over the life of the print run. The enzyme ink is approximately 63% water. A constant water content ensures that the amount of ink laid down onto the substrate 242 is consistent. If the water content of the ink changes during the printing process, this can lead to variations in the enzyme layer thickness. Additionally, loss of moisture from the enzyme ink shall lead to the enzyme drying on screen 301 resulting in poor print definition and a reduction in the amount of ink laid onto substrate 242. The humid air inside either first enzyme print station 105 or second enzyme print station 106 is maintained between 85 to 95% relative humidity. Top humid air 300 and bottom humid air 302 is pumped onto both sides of screen 301 to maintain the desired relative humidity. A side pipe 305 is arranged to one side of the web and introduces humidified air to the web on one side immediately adjacent the enzyme print stations. The nature and type of humidification arrangements can be varied to suit the size and shape of the print station and the humidification requirements of that type of ink at that print station

in that environment. Often a hood can be used to enclose the upper and/or lower side of the screen so that humidified air can be delivered into the hood directly adjacent the screen and retained within the vicinity of the screen by the presence of the hood. If the hood is mounted on the upper screen frame, as is typically the case, the hood may have a slot in the x direction (the direction of printing) to allow the squeegee to move in relation to the screen during the normal flood/print cycle.

Figure 4 is a bottom view depicting the humid environment around a fifth and sixth sections of the web printing. The basic components used to provide the means for humidification of the web printing environment are also illustrated in Figure 4 which includes top humid air 300, screen 301, bottom humid air 302, pipe with perforations 304, and perforations 400, side pipe at 305 (not shown). A pipe 304 with several perforations 400 is positioned underneath screen 301 as a means for blowing bottom humid air 302 to maintain the viscosity of the enzyme ink on screen 301. Figure 5 is a perspective view of pipe 304 with perforations 400 to blow bottom humid air 302.

Figure 8 is a schematic diagram depicting 2 different squeegee angles which includes a substrate 242, print roller 600, and squeegee 606. The angle of the squeegee 800 can be varied to optimize the definition of the print area. In an embodiment of the invention the angle of the squeegee can be  $15 \pm 5$  and preferably  $\pm 1$  to 2 degrees. Note that the contact point of the squeegee 606 to print roller 600 is the same for every squeegee angle 800.

Figure 9 is a schematic diagram depicting 2 different squeegee positions which includes substrate 242, print roller 600, lower print roller 303, squeegee 606, first squeegee position 900, and second squeegee position 901. The squeegee position is the position of the squeegee relative to the center of the print roller 600. The squeegee position can have a major effect on the thickness of printed ink. The position of the squeegee can be varied to optimize the definition of the print area.

Figure 10 is a schematic diagram depicting a screen snap distance (1000) which includes substrate 242, print roller 600, lower print roller 303, and screen 301. In one embodiment of the invention, screen snap distance (1000) is the closest distance between screen 301 and substrate 242. In a preferred embodiment of this invention, screen snap setting (1000) may be approximately 0.7mm. If the screen snap setting (1000) is set too high, squeegee 606 cannot sufficiently deflect screen 301 to transfer ink 604 onto substrate 242 with sufficient print definition. If the screen snap setting (1000) is set too low, screen 301 will smear ink 604 from a previous print cycle causing insufficient print definition.

Figure 11 illustrates an exploded view of a preconditioning zone 211 which comprises first drive roller 210, hot plate 1100, first heater bank 1101, second heater bank 1102, and third heater bank 1103. In an embodiment of the invention, hot plate 1100 contacts the unprinted side of substrate 242. In a preferred embodiment of this invention, hot plate 1100 may be coated with Teflon and may be heated to approximately 160°C. In an embodiment of the invention, first heater bank 1101, second heater bank 1102, and third heater bank 1103 blow hot air at approximately 160°C. This may be varied to suit the substrate type and/or thickness and/or any pretreatment and/or later temperatures encountered in the process as would be understood by those skilled in the art.

Figure 12 illustrates an exploded view of a first drying zone 217 which comprises second chilled roller 218, second drive roller 216, first drier bank 1200A, second drier bank 1101A, third drier bank 1102A, and fourth drier bank 1103A. In an embodiment of the invention, first drier bank 1200A, second drier bank 1101A, third drier bank 1102A, and fourth drier bank 1103A blow hot air at approximately 140°C although this may be varied as would be understood by those skilled in the art from the description herein.

Figure 13 illustrates an exploded view of a second drying zone 224 which comprises third drive roller 223, first drier bank 1200B, second drier bank 1101B, third drier bank 1102B, and fourth drier bank 1103B. In an embodiment of the invention, first drier bank 1200B, second drier bank 1101B, third drier bank 1102B, and fourth drier bank

1103B blows hot air at approximately 140°C although this may be varied as would be understood by those skilled in the art from the description herein.

Figure 14 illustrates an exploded view of a third drying zone 230 which comprises fourth drive roller 229, first drier bank 1200C, and second drier bank 1101C. In an embodiment of the invention, first drier bank 1200C and second drier bank 1101C, blows hot air at approximately 50°C although this may be varied as would be understood by those skilled in the art from the description herein.

Figure 15 illustrates an exploded view of a fourth drying zone 236 which comprises fifth drive roller 235, first drier bank 1200D, and second drier bank 1101D. In an embodiment of the invention, first drier bank 1200D and second drier bank 1101D, blows hot air at approximately 50°C although this may be varied as would be understood by those skilled in the art from the description herein.

Figure 16 illustrates an exploded view of a first cleaning unit 204 which comprises tacky rollers 1600, blue polymer rollers 1601. In an embodiment of the invention, blue polymer rollers 1601 contact the top and bottom side of substrate 242 and transfers particulate/foreign material to tacky rollers 1600.

Figures 17A to 17D illustrate views of an insulation layer to carbon layer print for an embodiment of the invention with proper registration. Note that Figure 17A represents the top left, Figure 17B the top right, Figure 17C the bottom left, and Figure 17D the bottom right of sensor sheet 2106. The marks are not shown on the sensor sheet illustrated in figure 21A. In one embodiment of this invention, carbon print station 103 prints carbon layer which comprises a solid carbon rectangle 1700 surrounded by a rectangular carbon line 1703 onto substrate 242. In a subsequent print cycle, insulation print station 104 prints rectangular insulation line 1701 onto substrate 242 which is positioned in between the solid carbon rectangle 1700 and the rectangular carbon line 1703. When the insulation layer to carbon layer registration is proper at all four corners typically there may be no uncoated substrate 242 showing between the rectangular



insulating line 1701 and solid carbon rectangle 1700. The registration of insulation layer to carbon layer can be checked manually by an operator or can be checked using second vision sensor 222, which in one embodiment comprises a camera pointed at each corner of the substrate. Typically this forms part of the initialization at the start of the print run. An operator can view all four corners of the substrate adjacent one another on a TV screen. The operator can then visually inspect the registration of insulation to carbon during this initialization process (and indeed during the remainder of the print run) and can make whatever adjustments are necessary to bring the insulation and carbon prints into registration. It should be appreciated that the web viewer 222 (comprising, for example, 4 cameras pointed at locations above four corner of the substrate card) views and forwards for display a snapshot of each of the four corners of each card. Thus the corners of each card are only viewed for a fraction of a second on the display since the substrate beneath the viewing cameras is constantly being replaced as the web travels through the apparatus. This system enables an operator to see instantly the effects any adjustment he may make has on the insulation to carbon registration. Adjustments the operator may make include, but are not limited to, screen print stroke, snap height, squeegee pressure, screen position relative to "Y" direction, screen position in relation to  $\theta$  (Theta). Once the viewer registration has been set up on this and other print stations (using viewers 228 and 234) the automatic internal X registration system (using marks 2107 and 2108) and the automatic Y registration system (for example, registration systems located at positions 237A, 237B and 237C using marks 2101 to 2104) are allowed to take over and monitor and automatically correct X and Y registration during printing. Marks 1700 to 1703 shown in figures 17A to 20 D can be used for automatic X and Y registration during printing as an alternative or in addition to using marks 2101 to 2104 and 2107 and 2108 as would be understood by those skilled in the art from the description herein.

Figure 18 illustrates a view of an insulation layer to carbon layer for an embodiment of the invention with improper registration when the insulation artwork is longer in the direction of printing than the carbon artwork. This may occur even if the carbon and insulation screen are the same size in this dimension because of the substrate may have stretched or the screen stroke may be different in each stage (a slower screen

stroke gives a relatively longer artwork print along the direction of travel of the substrate web). Note that Figure 18A represents the top left, Figure 18B the top right, Figure 18C the bottom left, and Figure 18D the bottom right of sensor sheet 2106. When the insulation layer to carbon layer registration is improper at one of the four corners uncoated substrate 242 can be observed between the rectangular insulating line 1701 and solid carbon rectangle 1700. The registration of insulation layer to carbon layer can be checked manually by an operator using second vision sensor 222.

Figure 19 illustrates a view of an insulation layer to carbon layer for an embodiment of the invention with improper registration when the printed insulation artwork is shorter than that of the carbon print (for example, the screen stroke for the insulation print may be longer than that of the carbon, or the insulation screen may be shorter than that of the carbon print station) Note that Figure 19A represents the top left, Figure 19B the top right, Figure 19C the bottom left, and Figure 19D the bottom right of sensor sheet 2106. When the insulation layer to carbon layer registration is improper at one of the four corners uncoated substrate 242 can be observed between the rectangular insulating line 1701 and solid carbon rectangle 1700. The registration of insulation layer to carbon layer can be checked manually by an operator using second vision sensor 222. Figures 20A to 20D are schematic diagrams depicting the results of a process for printing a second view guide 2002 (see Figure 21A) which comprises solid carbon rectangle 1700, hollow insulation rectangular line 1701, hollow carbon rectangle 1703, solid rectangle from the first enzyme layer 2000, solid rectangle from the second enzyme layer 2001, and uncoated substrate 242. Optionally, such prints can also be used during manufacture by automatic ongoing inspection systems such as inspection system 237 in section 6 (after the second enzyme print). Ongoing registration is typically otherwise carried out by a registration system (not shown) at positions 237A, 237B and 237C in the "Y" direction and by a registration control system looking at marks 2105 (see figure 21A) in the "X" direction).

Figure 21A is an example of a sensor sheet with a first view guide 2100 and second view guide 2002; first Y registration marks 2101, second Y registration marks

2102, third Y registration marks 2103, and fourth Y registration marks 2104; and X registration marks 2105. Note that X registration marks 2105 comprises carbon X registration mark 2107 and insulation X registration mark 2108. Figure 21B is an exploded view of one row within sensor sheet 2106 with a carbon X registration mark 2107 and second view guide 2002. Figure 21C is an exploded view of one row within sensor sheet 2106 with an insulation X registration mark 2108 and second view guide 2002. Insulation X mark 2108 entirely overcoats carbon X registration mark 2107 as illustrated in Figure 21C and in doing so provides a trigger point (left hand edge say of mark 2108) in advance of that of the original carbon mark 2107. This means that any subsequent layers are printed in relation to the second printed layer (in this case the insulation layer) rather than the carbon layer. This can be useful say if the second and subsequent screen artwork dimensions are longer in the X direction (along the web) than the first screen artwork dimension in the X direction.

An exploded view of one corner of the print guides is shown in Figure 20A-D, in the sequence in which they are printed. At section 3 of carbon print station 103, a solid carbon rectangle 1700 is printed along with a rectangular carbon line 1703, which surrounds the solid carbon rectangle 1700. At section 4 of insulation print station 104, a rectangular insulation line 1701 is printed between the solid carbon rectangle 1700 and the rectangular carbon line 1703. When insulation to carbon registration is correct at all four corners typically there will be no uncoated substrate 242 showing between solid carbon rectangle 1700 and rectangular insulating line 1701. Additionally, at section 4 of insulation print station 104, there are two more rectangular insulation lines 1701 printed directly above the solid carbon rectangle 1700. These two additional insulation lines are used to visually assess the registration of first enzyme layer 2000 to the insulation layer and second enzyme layer 2001 to the insulation layer, this is done so by printing a solid rectangle of enzyme ink within the rectangular insulation line as illustrated in Figure 20C and 20D. Thus the third and fourth printed layers can be registered to the second and not to the first printed layers. This has the advantage that a change in artwork size between the first and second layers (which may be required should the substrate stretch after the first print station for example due to the heat and tension encountered in the first drying zone 217)

can be accommodated without adverse effect on print registration (a tolerance of 300 $\mu$ m is typical in the X direction).

As illustrated in Figures 1 and 2, at the end of the process, substrate 242, including the sensors printed thereon is rewound by rewinder unit 107 and is then fed into punch 108, which may be, for example, a Preco punch which is located within a low humidity environment. The Preco Punch is a CCD X, Y, Theta, Floating Bolster Punch. The Preco Punch registration system uses a CCD vision system to look at "Preco Dots" which are printed on the Carbon print station, these allow the punch to adjust to the carbon print and enable the punch to "punch" the cards out square. The output of Punch 108 is a set of punched cards such as those illustrated in Figure 21A. Punched cards are ejected from punch 108 onto a conveyer belt, this conveyer belt transports the cards under a barcode reader which reads two of the barcodes on each card to identify whether the card is accept or reject in relation to the Web Database. Automatic or manual extraction of rejected cards can carried out. The cards are then stacked on top of one another in preparation for the next manufacturing step.

At carbon print station 103, insulation print station 104, first enzyme print station 105, and second enzyme print station 106 all have a means for visually inspecting the registration immediately after the printing process step using first vision sensor 215, second vision sensor 222, third vision sensor 228, fourth vision sensor 234, respectively. For each section in the web printing manufacturing process – Section 3, 4, 5 and 6 - there are Web Viewer camera systems located immediately after the printing process step. See Figure's 2A-2C for web viewer locations. There are two cameras at Section 3 and four cameras each at Section 4, 5 and 6. The web viewer cameras are part of a manual set-up process used by the Web machine operators during the start of the print run. The cameras are used to view printed marks, which aid the initial set-up of carbon alignment to substrate 242 and registration between insulation layer to carbon layer, first enzyme layer to insulation layer, and second enzyme layer to insulation layer. The printing guides are illustrated indicated on Figure 21A. For carbon print alignment, second view guide 2100 is used to indicate the carbon print position in relation to the edge of substrate 242 as it runs

through carbon print station 103. There is a leading line and a trailing line as illustrated in Figure 21A. The carbon print is adjusted until the lines indicate that the print is square to the substrate edge. Registration of the individually printed layers is required in the X direction (along the length of the machine) and the Y direction (across the width of the machine) See Figure 21A. X direction registration is controlled by the internal registration system of the machine. This utilizes the printed areas indicated on Figure 21A, B and C. On the Carbon print cycle a carbon X registration mark 2107 is printed in this area. The Insulation printing cycle is registered to the Carbon print using sensors which use carbon X registration mark 2107 to allow the insulation screen to adjust in order to print the insulation ink in the correct position. The carbon X registration mark 2107 used for this purpose is then over printed with insulation X registration mark 2108 and is utilized in the same manner to correctly register first enzyme layer 2000 and second enzyme layer 2001 with the insulation print. Y direction registration is controlled by Y registration system (not shown) located at positions 237A, 237B and 237C which in one embodiment of the invention may be an Eltromat registration system, model number DGC650 from Leopoldshöhe, Germany. This utilizes the printed areas 2101 to 2104 indicated in Figure 21A. On each print cycle – Carbon, Insulation, Enzyme1 and Enzyme2 – these marks are printed in order that the subsequent print is registered, via sensors, in the Y direction. The Web Database records process information during printing. Information recorded in the database can be traced back to each individual card via a barcode, in one embodiment a 2D barcode is used. Typical information gathered in the Web database is outlined in Table 3. The Web Database has the ability to assess whether a process parameter is Acceptable or Unacceptable and can be used to reject cards on this basis – whether the parameters were running within there tolerance limit. Unacceptable cards may be removed at future processes either manually or automatically.

Table 3.

Section 2 Pre Condition	Section 3 Carbon	Section 4 Insulation	Section 5 Enzyme	Section 6 Enzyme
Hot Plate 1 of	Drier Bank 1	Drier Bank 1	Drier Bank 1	Drier Bank 1

1	of 2	of 3	of 4	of 4
Drier Bank 2 of 1	Drier Bank 2 of 2	Drier Bank 2 of 3	Drier Bank 2 of 4	Drier Bank 2 of 4
Drier Bank 3 of 1	Drier Bank 3 of 2	Drier Bank 3 of 3	Squeegee Pressure	Squeegee Pressure
Drier Bank 4 of 1	Drier Bank 4 of 2	Drier Bank 4 of 3	Inside Hood %RH	Inside Hood %RH
	Squeegee Pressure	Squeegee Pressure	Inside Hood Temp	Inside Hood Temp
			Outside Hood %RH	Outside Hood %RH
			Outside Hood Temp	Outside Hood Temp
Web Tension				
Web Speed				

Figure 22 is a schematic diagram of parameters X, Y, Z, and  $\theta$  used to register the web printing process. The parameter Y represents the direction from the operator to the machine side of the web printing machine (typically horizontal). The parameter X represents the direction from unwind unit 101 to rewinder unit 107 (typically horizontal). The parameter Z represents the direction perpendicular to the X and Y directions (typically vertical). The parameter  $\theta$  represents the angle around the Z axis. In an embodiment of this invention, the following parameters are used to register the following print process such as, for example, carbon print station 103, insulation print station 104, first enzyme print station 105, and second enzyme print station 106.

In one embodiment of the present invention, the output of the web manufacturing process is cards printed with artwork comprising Carbon, Insulation and two identical Enzyme layers printed in register with one another to form strips each containing an electrochemical sensor and associated contact electrodes for detecting Glucose in a blood sample. The strips are used for self-monitoring of blood glucose in conjunction with a meter. Productions of several designs of strips are envisaged. At present the web is designed to produce "One Touch Ultra" strips for use in the One Touch Ultra meter which is available from LifeScan, Inc.

A schematic diagram sample of the artwork produced is in Figure 21A. This illustrates one complete printed card, which contains 10 "Rows" of 50 "Strips". There are a total of 500 "Strips" per card. Print orientations are also indicated. By printing rows 0 to 9 (each of 50 strips) parallel to the direction of print, the process can be easily extended to inclusion of a cutting step separating one row from another. Furthermore this means that any defective rows resulting from cross web variation in print quality (perpendicular to the direction of print) can be identified easily. Each row is allocated a number (identified by a barcode) and therefore specific rows from specific sheets on the web can later be identified with reference to the database and eliminated without the need to reject the whole sheet. This increases the yield of usable product from the process and renders the whole process more efficient.

The movable substantially flat screen copes well with the types of ink (solid/liquid combinations) used in the printing of electrochemical sensors. The use of a movable flat screen can enable better control of print definition and the deposition of the thicker layers of ink needed in electrochemical sensors than may be allowed by rotogravure or cylinder screen printing. A variety of types of screen (with different mesh, diameter of thread in the mesh, thread separation, thickness, mesh count) are readily commercially available to cope with the different requirements of different types of ink in the continuous web printing process (carbon, insulation, enzyme).

Because of the arrangement of the flat screen, print roller, substrate and a squeegee urging the screen towards the substrate, a variety of parameters are available to be manipulated (screen to substrate angle, squeegee angle, screen to squeegee position, squeegee to print roller position, snap distance, relative speeds of substrate and screen and squeegee etc) to optimize the print process for electrochemical sensors.

To summarize briefly in a web manufacturing process for manufacturing electrochemical sensors, the web expands or stretches as it is heated up and placed under tension during the process. The printing stations (for example carbon, insulation, two enzyme) typically each are followed by a drying station. In order to dry the inks efficiently the drier stations operate at quite high temperatures (50-140 degrees centigrade). Furthermore to aid registration of the web through each printing station, the web is placed under tension.

The substrate has to be kept under tension to control registration within the process, as a result, whenever the substrate is heated for example to dry the inks after printing, the substrate will stretch unpredictably causing image size variation in subsequent prints.

The size of the image printed at each print station is determined by several factors (stencil size, ink viscosity, relative web and stencil/screen speed and substrate stretch at that point (both reversible and irreversible stretch) etc) The image size variation (between different printing steps) when looked at the end of the process was found to vary. It was unpredictable and higher than expected significantly reducing yields. If the mismatch between image sizes between layers is greater than 300microns along the web (x-direction), the product will not work. The excessive image size variation was thought to be due to excessive and unpredictable stretching (due to heating and tension) and shrinking of the web substrate.

The problem of stretch and tension does not cause the same problems in flat bed printing. To solve the problem in the web process, pre-shrunk substrate was tried. The



substrate was heated to around 185 degrees centigrade before being used in the web process. However, the variation in image size remained a problem, and caused reduced yields.

The current proposal for the web process is the use of high temperatures in a first drier or rather preconditioned at a sufficiently high temperature so that in one example, irreversible stretch is substantially removed from the substrate, prior to an image being printed on the substrate.

In a first processing station in the web machine, a drier bank heats the substrate up to 160 degrees centigrade. The temperatures encountered by the substrate later in the process, typically do not exceed 140 degrees.

In figure 2A the first heater bank that the unprinted substrate encounters is the hot plate. This is a Teflon coated plate, which lifts and contacts the substrate during motion of the web. The heat is introduced to the back face of the substrate. This is currently running at a set point of 160°C with a specification of +/- 4°C. The 160°C set point statistically provided the best dimensional control. The calculated mean is 160.9°C. In Bank 2 hot air is introduced to the front face of the substrate at a set point of 160°C with a specification of +/- 4°C. The calculated mean is 161.29°C. In Bank 3 hot air is introduced to the front face of the substrate at a set point of 160°C with a specification of +/- 4°C. The calculated mean is 161.18°C. In Bank 4 hot air is introduced to the front face of the substrate at a set point of 160°C with a specification of +/- 4°C. The calculated mean is 160.70°C.

As a result of the web tension and the heat introduced in the drier, the web substrate is stretched by approximately 0.7mm per artwork repeat. This was one of the primary reasons for utilizing Station 1 as a preconditioning unit to stabilize the substrate prior to subsequent printing stations. The use of Station 1 to precondition the substrate improves the stability of Carbon and Insulation Row Length since much of the material stretch has been removed from the substrate prior to printing.

In one embodiment of the present invention, high temperatures are used in a first drier at a sufficiently high temperature so that irreversible stretch is substantially removed from the substrate prior to any image being printed on the substrate (i.e. prior the substrate reaching any print stations). In a first processing station in accordance with the present invention, a drier bank heats the substrate to a first temperature which is substantially higher than any temperature the substrate will encounter during the printing process. For example, if the highest temperature the substrate will encounter during the printing process is 140 degrees centigrade, the first temperature may be on the order of approximately 160 degrees centigrade.

A method according to the present invention may be described by the following steps. The steps including pre-conditioning a continuous substrate by heating to a first temperature; printing an electrode layer on the substrate; exposing the electrode layer to a heat source so that the electrode layer is heated to a second temperature; optionally, the first temperature is greater than the second temperature. In further embodiments, the method may also include the steps of printing an insulation layer on a continuous substrate; exposing the insulation layer to a heat source so that the insulation layer is heated to a third temperature wherein the the first temperature may be greater than the third temperature.

In a further embodiment of the present invention, the substrate is pulled off a roll at a predetermined tension and passed over a first heater bank which, in one embodiment may be a Teflon coated hot plate. The hot plate lifts and heats the substrate as it passes over the hot plate. Heat is thus introduced to the back face of the substrate. The hot plate may be adjusted to heat the substrate to a temperature of approximately 1600C +/- 50C. The substrate then moves to a second heater bank where side of the substrate opposite the hot plate is heated by hot air which has a temperature of approximately 1600C with a specification of +/- 50C. The substrate then moves to a third heater bank where side of the substrate opposite the hot plate is heated by hot air which has a temperature of approximately 1600C +/- 50C. The substrate then moves to a fourth heater

bank where side of the substrate opposite the hot plate is heated by hot air which has a temperature of approximately 1600C +/- 50C.

As a result of the web tension and the heat introduced in the drier, the web substrate is preconditioned, thus reducing the stretching in subsequent process steps in a continuous manufacturing process.

It will be recognized that equivalent structures may be substituted for the structures illustrated and described herein and that the described embodiment of the invention is not the only structure which may be employed to implement the claimed invention. In addition, it should be understood that every structure described above has a function and such structure can be referred to as a means for performing that function.

While preferred embodiments of the present invention have been shown and described herein, it will be obvious to those skilled in the art that such embodiments are provided by way of example only. Numerous variations, changes, and substitutions will now occur to those skilled in the art without departing from the invention. It should be understood that various alternatives to the embodiments of the invention described herein may be employed in practicing the invention. It is intended that the following claims define the scope of the invention and that methods and structures within the scope of these claims and their equivalents be covered thereby.

## CLAIMS

## WHAT IS CLAIMED IS:

1. A method of preconditioning a substrate in a web manufacturing process wherein said web manufacturing process includes a plurality of printing steps, said method comprising the steps of:
  - moving said substrate through said web process under tension;
  - heating said substrate as said substrate is passed through said printing steps, wherein said substrate temperature does not exceed a first predetermined temperature during said printing steps; and
  - passing said substrate into a preconditioning station wherein said substrate is heated to a second predetermined temperature which exceeds said first predetermined temperature.
2. A method according to Claim 1 wherein said second predetermined temperature is not met or exceeded during subsequent stages of said web process.
3. A method according to Claim 2 wherein said second predetermined temperature is approximately 140°C.
4. A method according to Claim 2 wherein said preconditioning station includes at least one surface cleaning station adapted to remove impurities from said substrate.
5. A method according to Claim 2 wherein said first predetermined temperature is approximately 160°C.

6. A method according to Claim 1 wherein said substrate is stretched at a predetermined tension prior to being heated to said second predetermined temperature.
7. A method according to Claim 6 wherein said predetermined tension is not exceeded during subsequent stages of said web process.
8. A method according to Claim 7 wherein said second predetermined temperature is not met or exceeded during subsequent stages of said web process.
9. A method according to Claim 8 wherein said preconditioning station includes at least one surface cleaning station adapted to remove impurities from said substrate.
10. A method according to Claim 7 wherein said predetermined tension is approximately 165N and said second predetermined temperature is approximately 140°C.
11. A method according to Claim 7 wherein said predetermined tension is approximately 165N and said first predetermined temperature is approximately 160°C.
12. A method according to Claim 1 wherein said second predetermined temperature is a temperature sufficient to remove the irreversible stretch from said substrate.

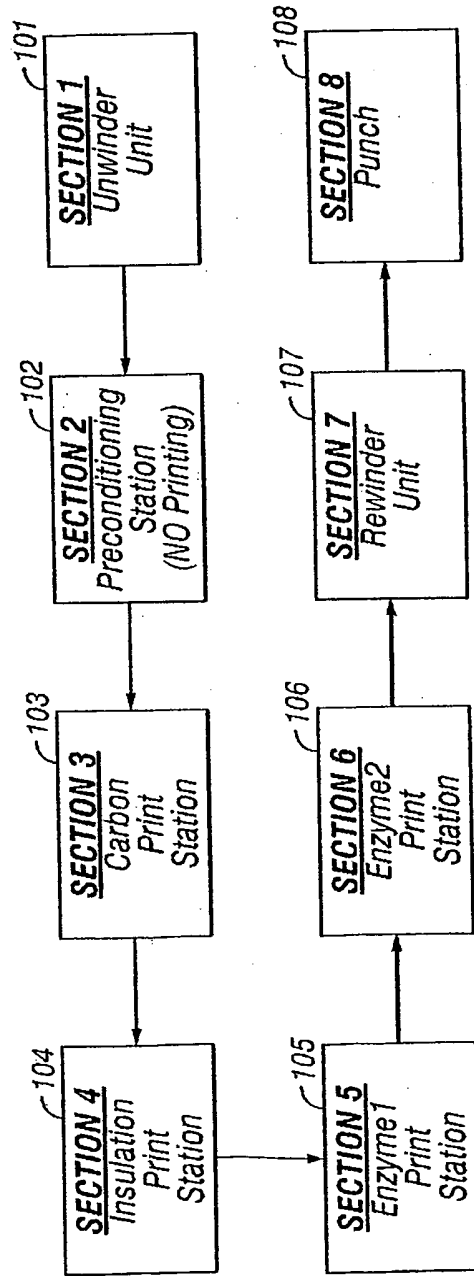
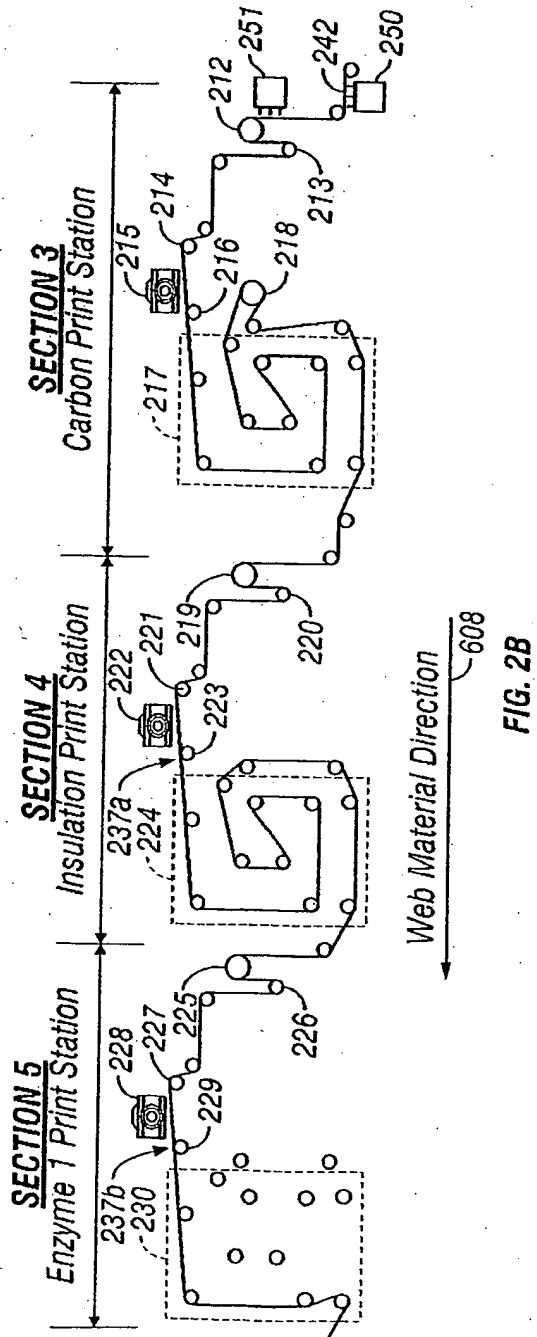
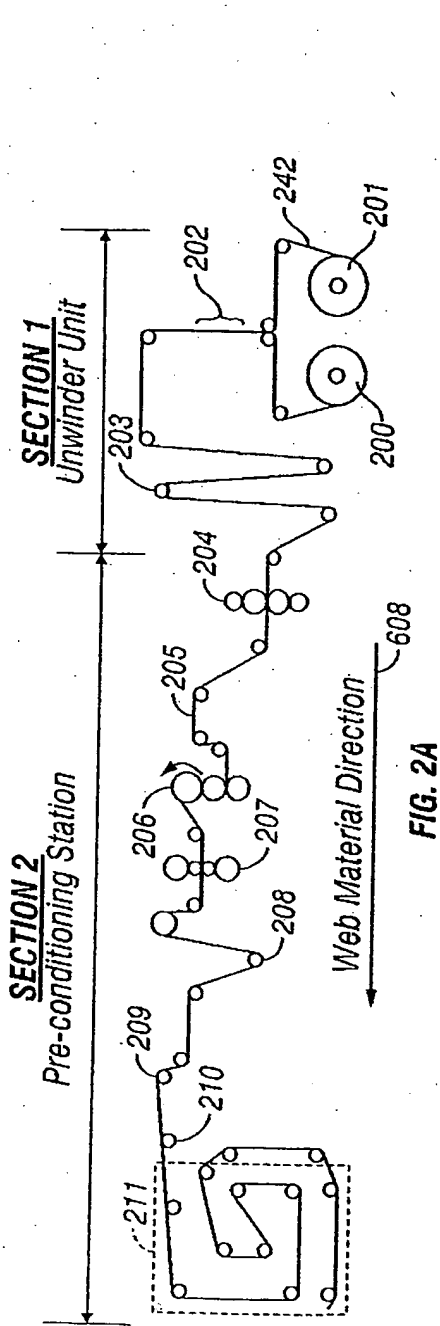

FIG. 1



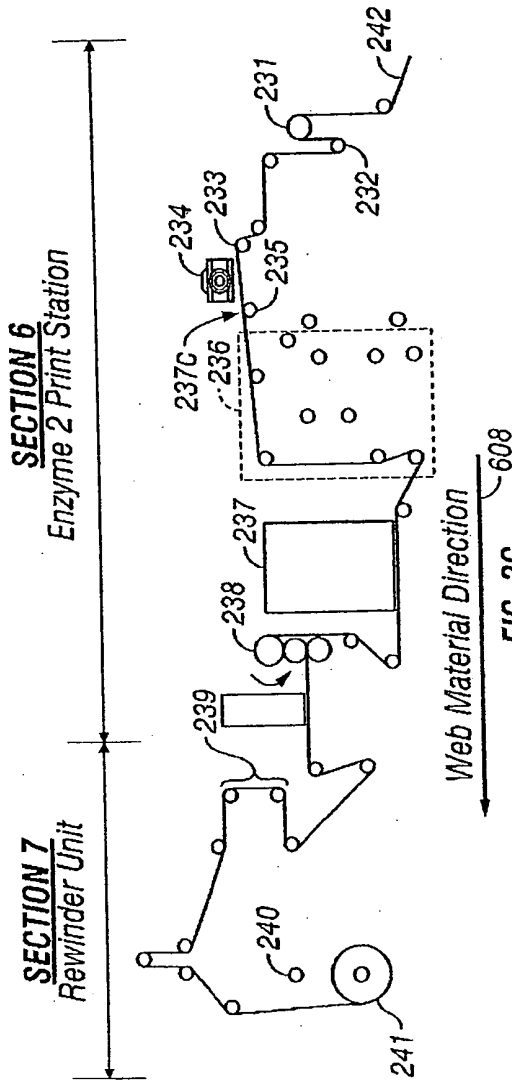

FIG. 2C

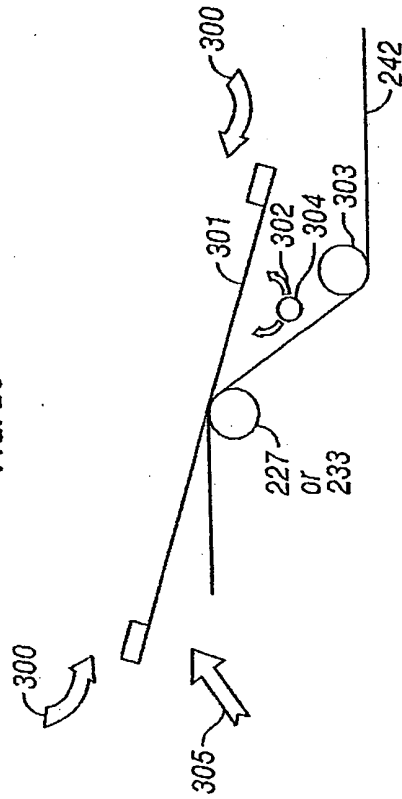

FIG. 3



4/14

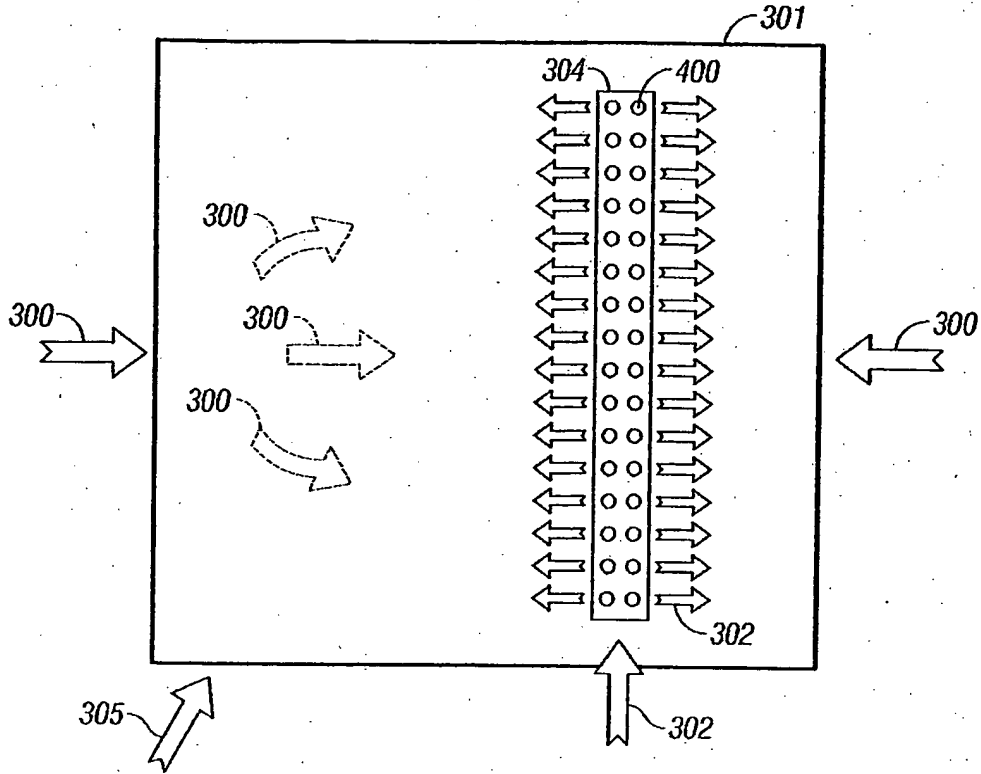

FIG. 4

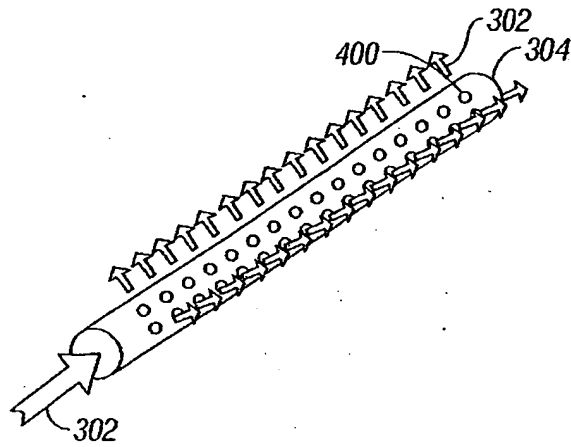

FIG. 5

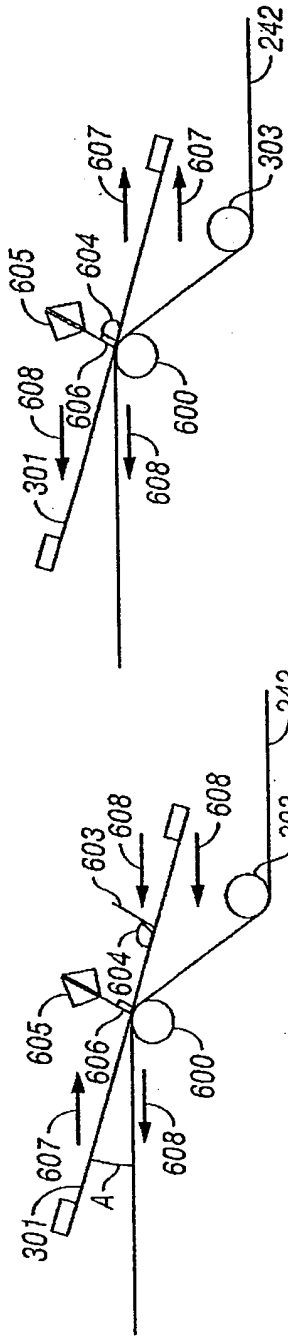

FIG. 6

FIG. 7

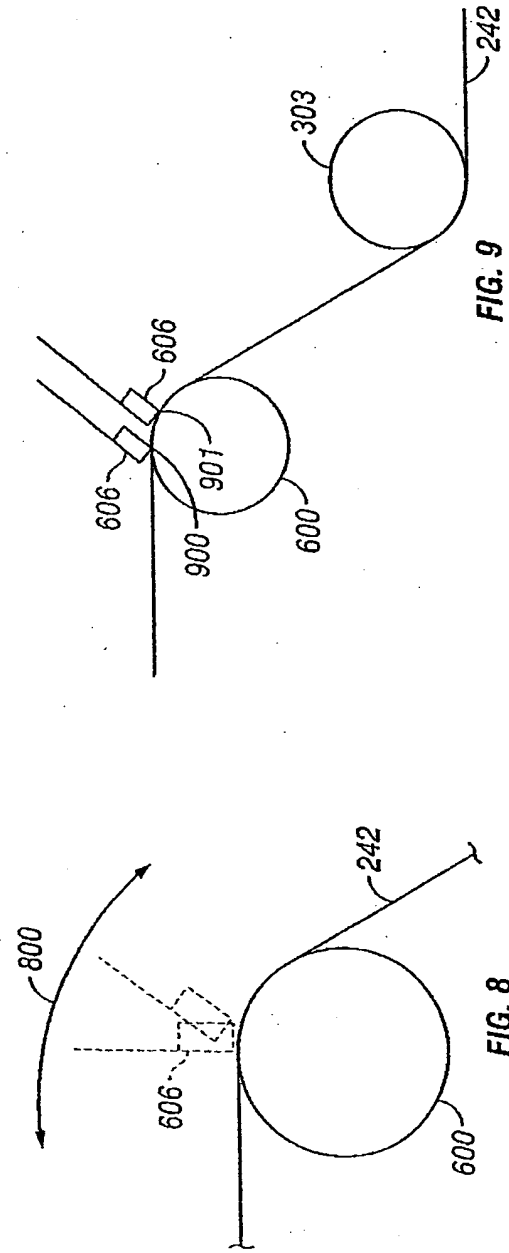

FIG. 8

FIG. 9

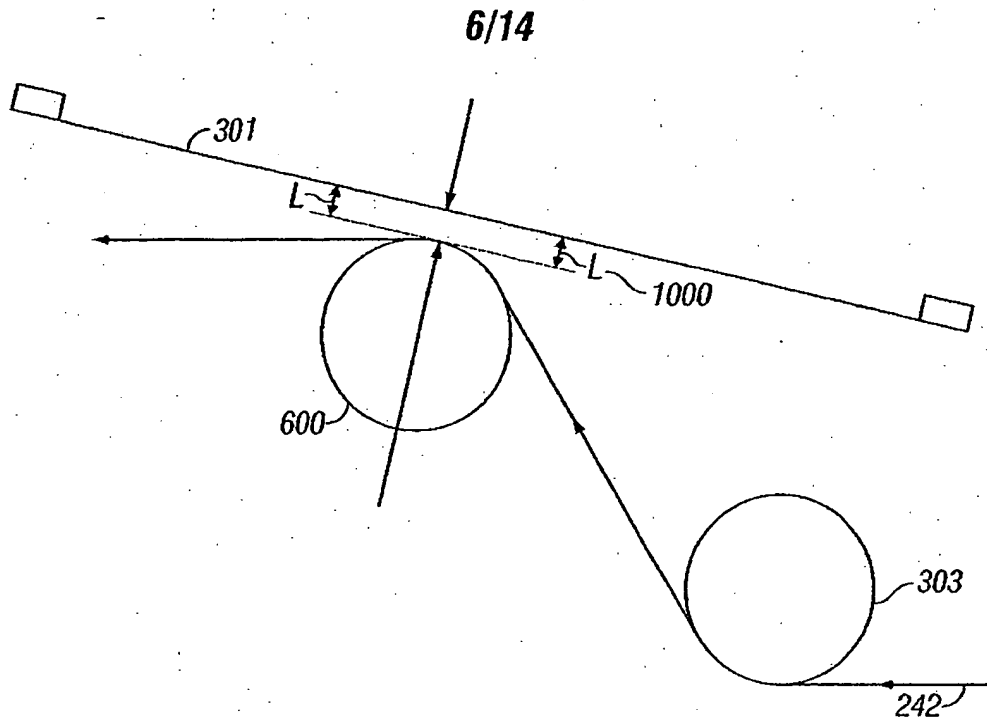

FIG. 10

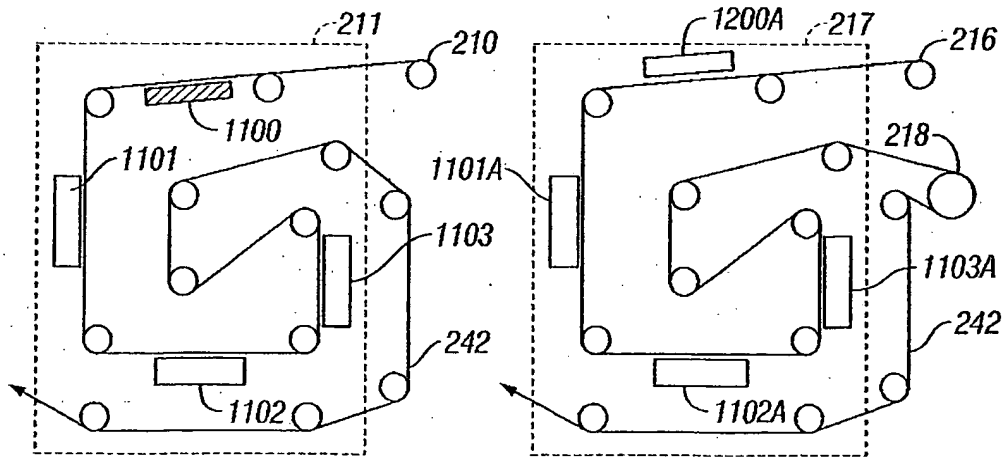

FIG. 11

FIG. 12

7/14

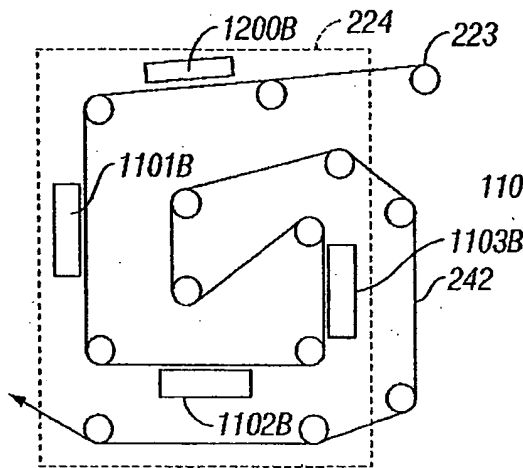

FIG. 13

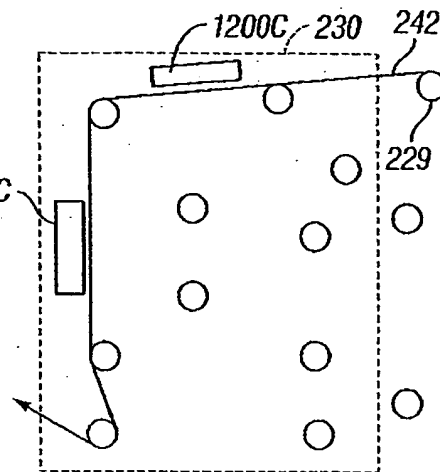

FIG. 14

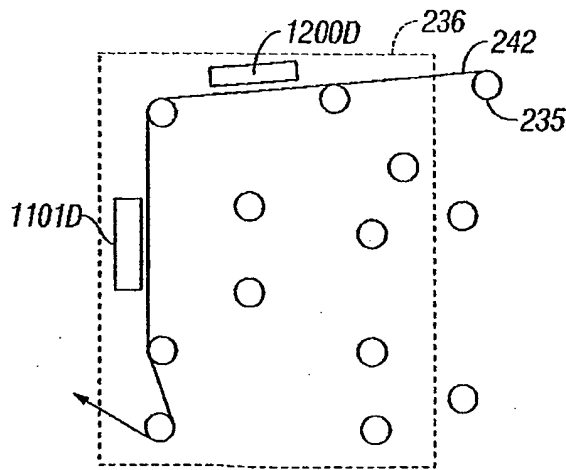

FIG. 15

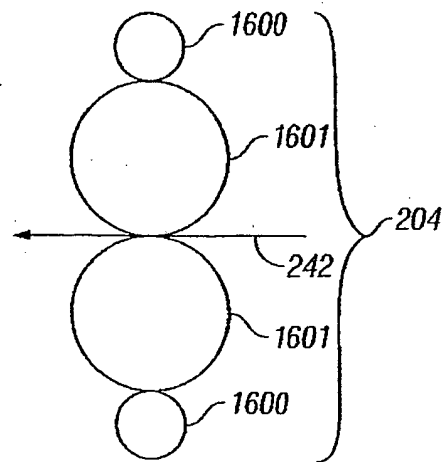
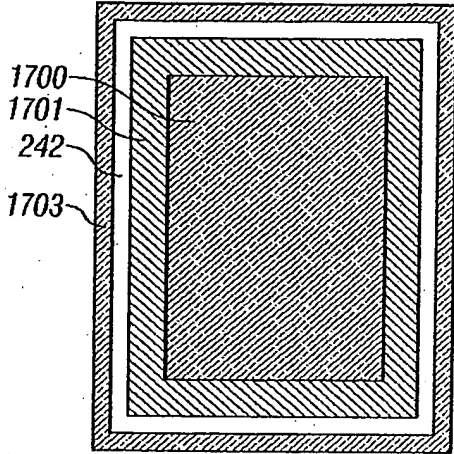

FIG. 16

*Top Left of Card*



**FIG. 17A**

*Top Right of Card*

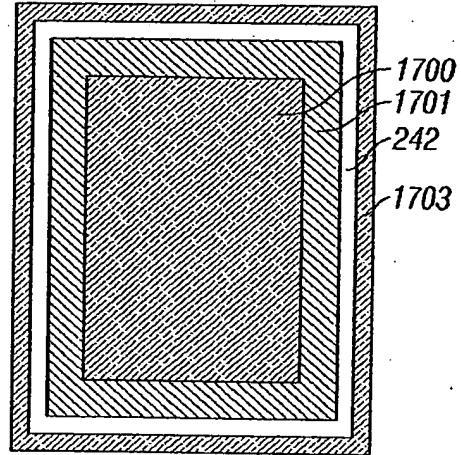

**FIG. 17B**

*Bottom Left of Card*

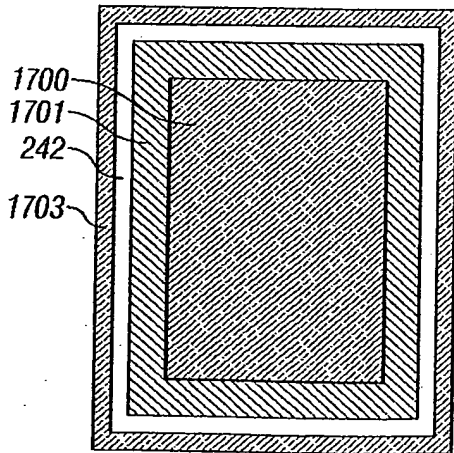

**FIG. 17C**

*Bottom Right of Card*

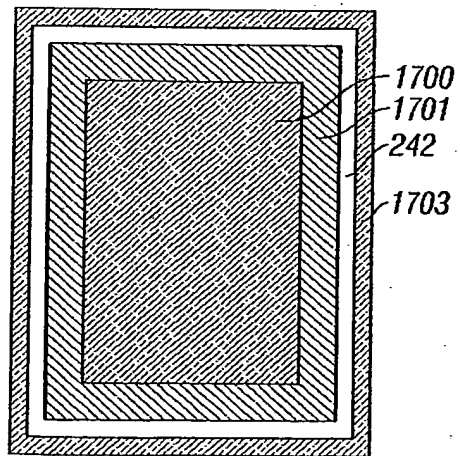

**FIG. 17D**

9/14

*Top Left of Card*

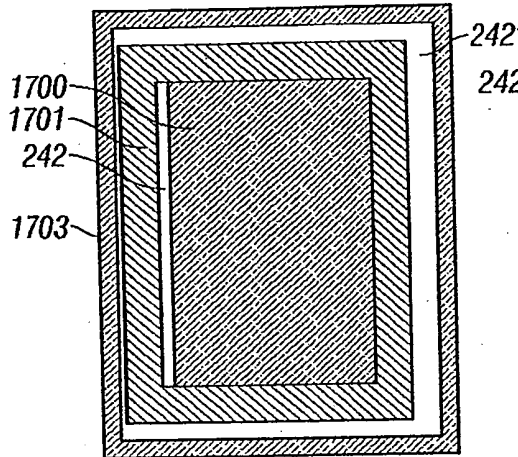

**FIG. 18A**

*Top Right of Card*

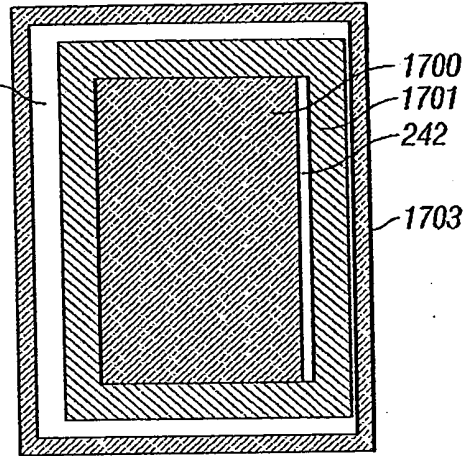

**FIG. 18B**

*Bottom Left of Card*

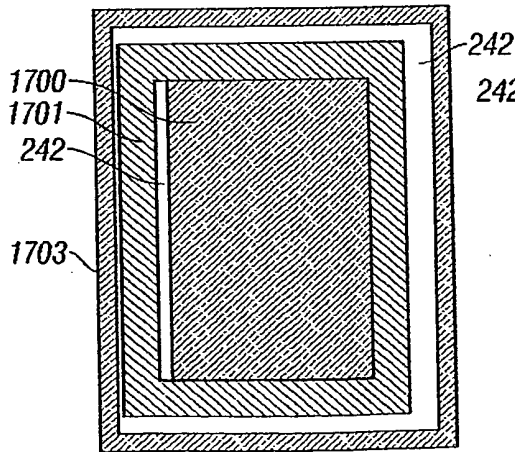

**FIG. 18C**

*Bottom Right of Card*

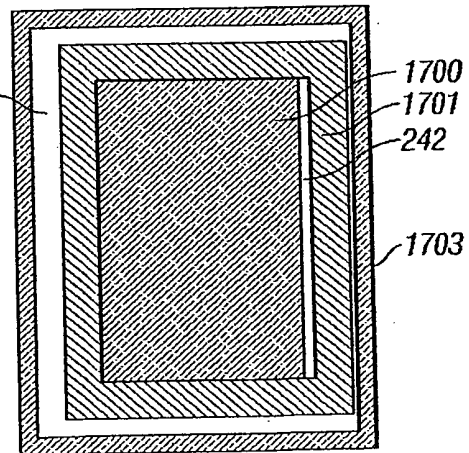

**FIG. 18D**

10/14

*Top Left of Card*

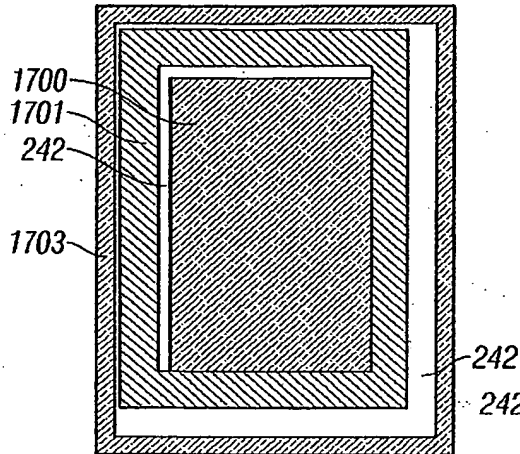

**FIG. 19A**

*Top Right of Card*

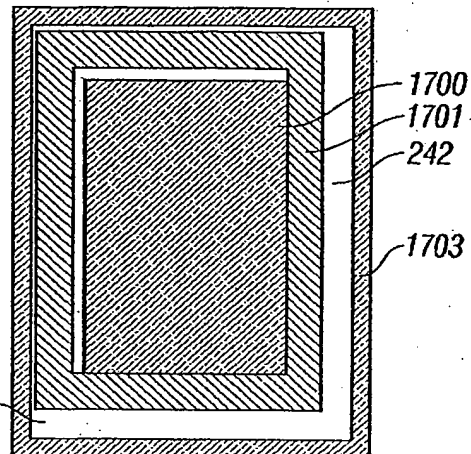

**FIG. 19B**

*Bottom Left of Card*

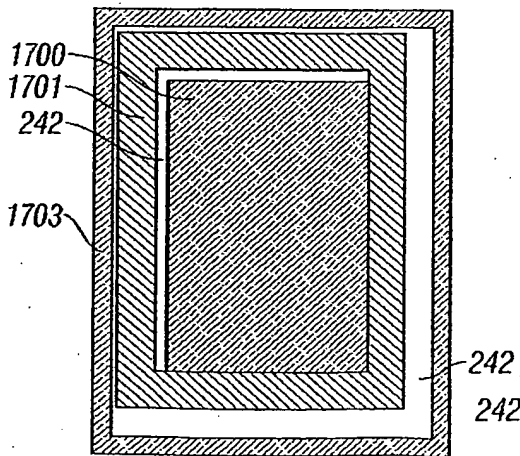

**FIG. 19C**

*Bottom Right of Card*

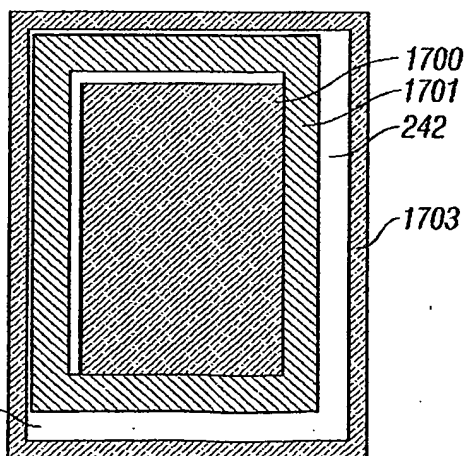

**FIG. 19D**

11/14  
2002

After Section 6 Print  
- Enzyme 2

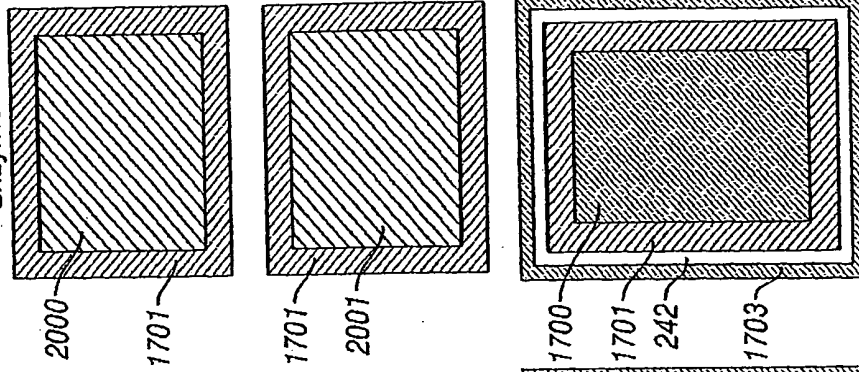

FIG. 20D

After Section 5 Print  
- Enzyme 1

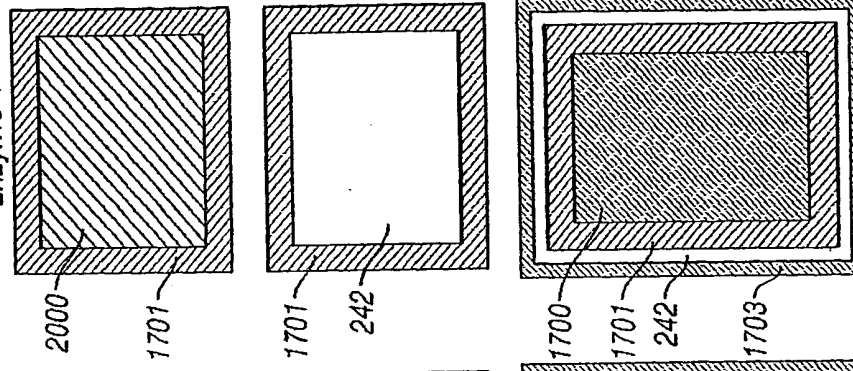

FIG. 20C

After Section 4 Print  
- Insulation

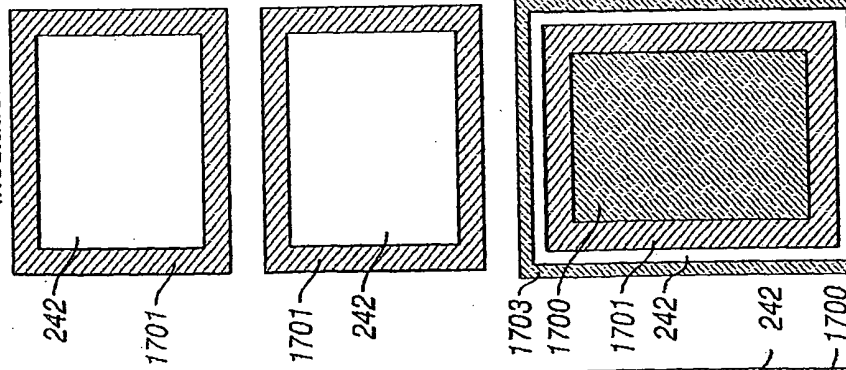

FIG. 20B

After Section 3 Print  
Carbon

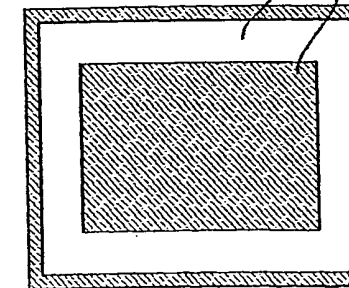

FIG. 20A



12/14

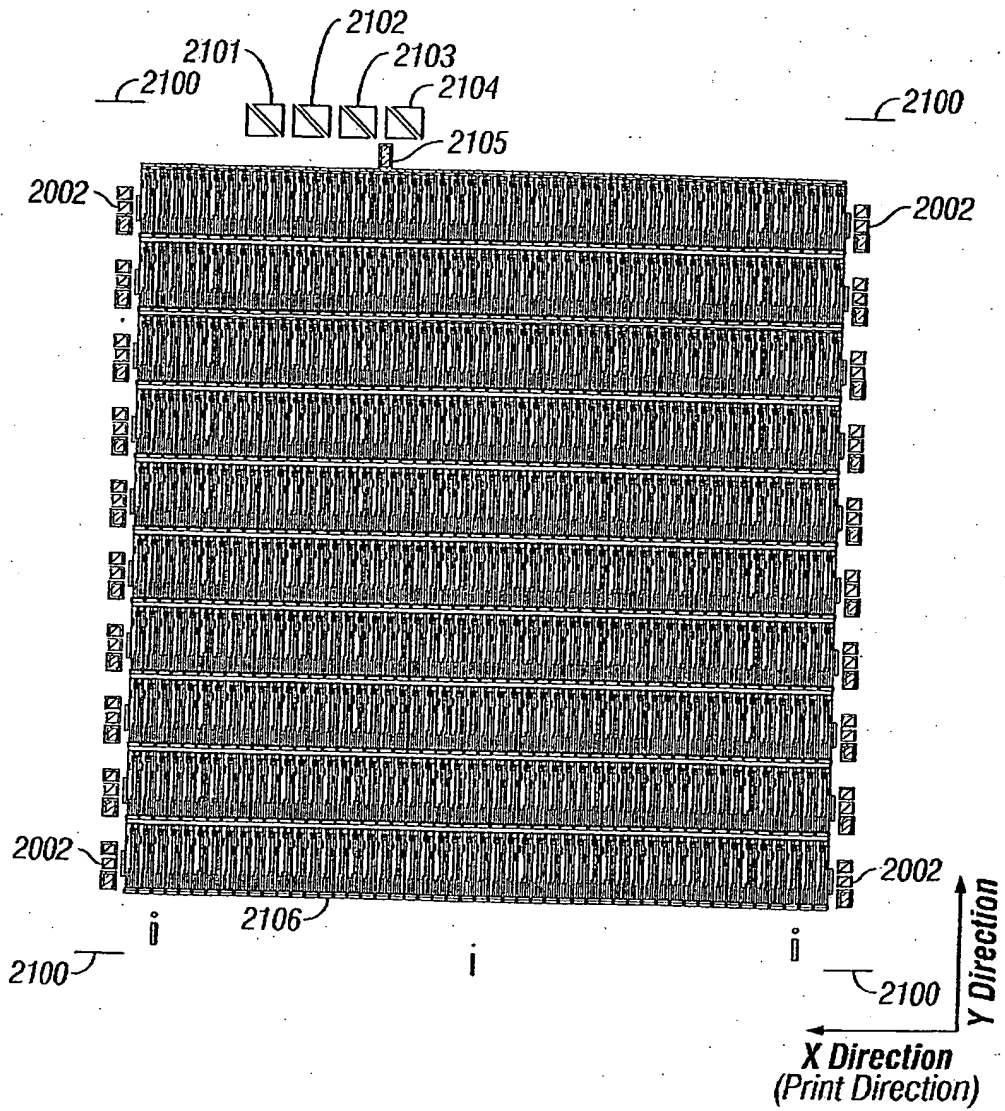

FIG. 21A

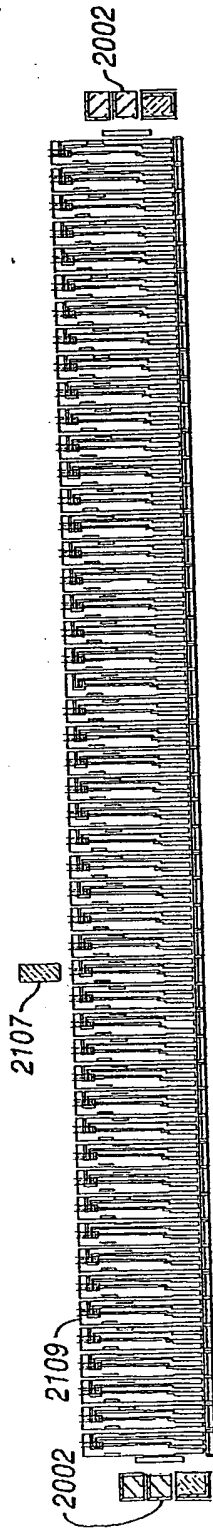

FIG. 21B

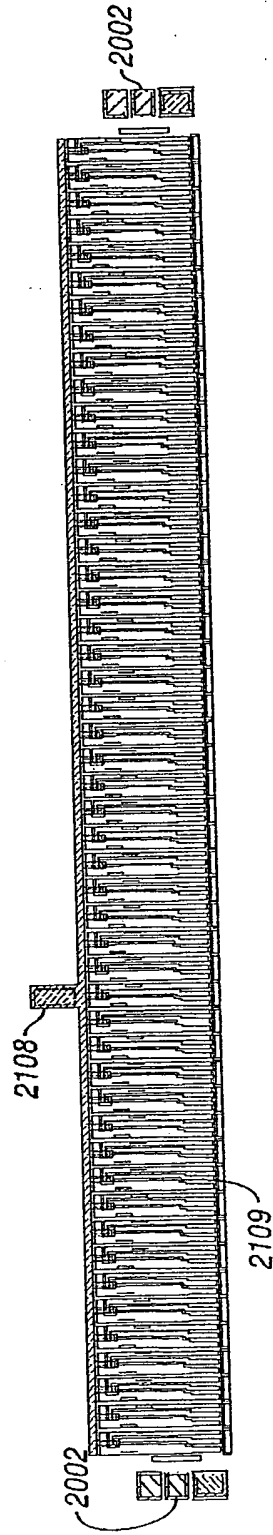

FIG. 21C

14/14

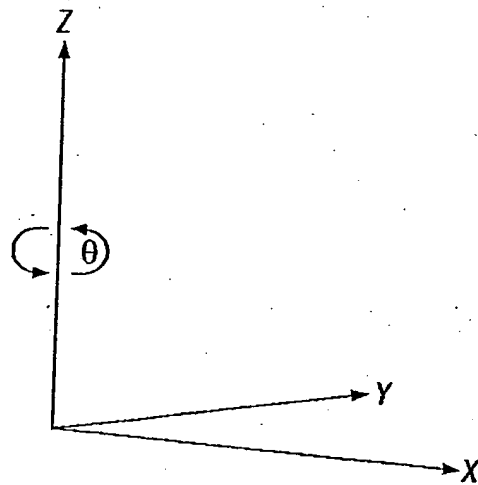

FIG. 22

**BLANK PAGE**